

Pfaff 1245
Old Casting

PFAFF

1245

Teileliste

Parts list

Liste de pièces

Lista de piezas

Die Inhaltsübersicht auf Seite 3 gibt einen Überblick über die Aufgliederung der Liste.
Die Teile sind so abgebildet, wie sie in der Maschine funktionsmäßig zusammengehören.
Die gestrichelten Abbildungen zeigen, wo die daneben abgebildeten Teile hingehören.
Die Einrahmungen auf den Bildseiten zeigen, aus welchen Einzelteilen sich die Gruppenteile zusammensetzen.
Nähwerkzeuge und Apparate sind der Unterklassen-Ausstattung zu entnehmen (siehe Anhang).
Die auf den Bildseiten verwendeten Schlüsselzeichen (; 2 ; 3 usw.) sind in Register "0" zusammengefaßt und erläutert.
Konstruktionsänderungen vorbehalten.

For the various sections of this catalogue, please refer to the "Contents" on page 3.
The parts are illustrated as they belong together in the machine.
The dashed illustrations show where the adjacent parts belong.
The framed-in sections on the illustration pages show the individual parts comprising a group.
For gauge parts and attachments please refer to the subclass listing (see appendix).
The keys used on the illustration pages (; 2 ; 3 etc.) are listed and explained in section "0".
Subject to alterations in design.

La table des matières, page 3, donne un aperçu de la subdivision de la liste.
Les pièces figurent sur l'illustration comme elles vont ensemble.
Les figures en tirets montrent le lieu de montage des pièces figurant à côté.
Les parties encadrées sur les pages à illustrations représentent les pièces individuelles formant groupe.
Pour les organes de couture et les appareils, veuillez vous référer à la fiche équipement de sous-classes (voir en annexe).
Les symboles (; 2 ; 3 etc.) utilisés sur les pages illustrées sont regroupés et expliqués au registre "0".
Sous réserve de modifications.



En la página 3, bajo el título "contenido", puede verse un resumen de la división de la "lista de piezas".
Las piezas están ilustradas conforme se hallan montadas en la máquina.
Las figuras a base de líneas entrecortadas muestran dónde y cómo van montadas las piezas ilustradas al lado.
Los recuadros en las páginas ilustradas indican las piezas individuales de que se componen los grupos.
Para los órganos de costura y aparatos, véase la "Composición de las subclases" (en el anexo).
Los símbolos clave (; 2 ; 3 etc.) utilizados en las páginas ilustradas se hallan recopilados y explicados en el registro "0".
Salvo modificaciones técnicas.

| Register Section Registre Registro | | Seite Page Página |
|---|--|--------------------------------|
| | Schiermittel-Tabelle Table of lubricants Tableau des lubrifiants Tabla de lubricantes | 5 |
| 0 | Erläuterungen Explanations Légende Explicaciones | 6 |
| 1 | Kopfteile Needle head parts Pièces de tête Piezas de la cabeza | PFAFF 1245-706/07 CN;CN8 10 |
| 2 | Armteile Arm parts Pièces de bras Piezas del brazo | PFAFF 1245-706/07 CN;CN8 13 |
| 3 | Grundplattenteile Bedplate parts Pièces du plateau fondamental Piezas del cárter | PFAFF 1245-706/07 CN;CN8 16 |
| 4 | Gehäuseteile Housing sections Parties du corps Piezas del cárter | PFAFF 1245-706/07 CN;CN8 19 |
| 5 | Kopfteile Needle head parts Pièces de tête Piezas de la cabeza | PFAFF 1245-706/47 CN 20 |
| 6 | Armteile Arm parts Pièces de bras Piezas del brazo | PFAFF 1245-706/47 CN 23 |
| 7 | Grundplattenteile Bedplate parts Pièces du plateau fondamental Piezas del cárter | PFAFF 1245-706/47 CN 27 |
| 8 | Gehäuseteile Housing sections Parties du corps Piezas del cárter | PFAFF 1245-706/47 CN 31 |
| 9 | Fadenabschneid-Einrichtung Thread trimmer Coupe-fil Cortahilos | -900/56 32 |
| 10 | Presserfuß-Automatik Automatic presser foot lifter Relève-pied automatique Alzaprensateles | -910/04 38 |
| 11 | Verriegelungs-Einrichtung Bactacking mechanism Dispositif à points d'arrêt Rematador | -911/35*) 40 |
| 12 | Wartungseinheit Air filter / lubricator Conditionneur d'air comprimé Grupo acondicionador del aire comprimido | -925/02 45 |
| 13 | Zubehörteile Accessory parts Accessoires Accesorios | 46 |

| Register Section Registre Registro | | Seite Page Página |
|---|--|-------------------------|
| 14 | Einstellehren Adjustment gauges Calibres Calibres de ajuste | 48 |
| 15 | Fadenöler Thread lubricator Graisseur de fil Lubrificador del hilo | 49 |
| 16 | Teile zur Fadenbremse Thread retainer components Pièces de frein de fil Piezas del frenahilos | 49 |
| 17 | Knielüfterteile Knee lifter parts Pièces de releveur de genouillère Piezas del alzaprensatelas por rodillera | 50 |
| 18 | Anschlußteile zum Pedal Connecting parts for pedal Raccords de pédale Piezas de empalme del pdeal | 52 |
| 19 | Motoranschlußsatz Motor connection kit Jeu de pièces à raccorder le moteur Juego de piezas de conexión del motor | 53 |
| 20 | Positionsgeber Synchronizer Synchronisateur Sincronizador | 55 |
| 21 | Keilriemenscheiben-Tabelle Table of V-belt pulleys Tableau des poulies à gorge en V Tabla de poleas para correas en "V" | 56 |
| 22 | Nummernverzeichnis Numerical index Tableau des numéros Indice numérico | 57 |
| Anhang Appendix Annexe Anexo | Unterklassen-Ausstattung Subclass parts Composition des sous-classes Composición de las subclases | |
| | | |
| | | |
| | | |
| | | |
| | | |
| | | |
| | | |

Lubrifiants
Lubricantes

PFAFF 1245

| Öl Oil Huile Aceite | Mittelpunkts- Viskosität bei: Mean viscosity at: Viscosité moyenne à: Viscosidad media a: | | Dichte bei: Density of: Densité à: Densidad a: | | Bestellnummer für Behälter mit: Part number for can with: Numéro de commande pour récipients avec: Número de pedido para recipientes con: | | | |
|------------------------------|---|-------|---|-----------------|--|---|---|---|
| | °C | mm²/s | °C | g/cm³ (g/ml) | Liter Litre Litros |  |  |  |
| 280-1-120 122 | 40 | 16,4 | 15 | 0,849 | 40(ml) | 91-027 624-91 | | |
| | | | | | 0,25 | | | |
| | | | | | 1 | | 91-129 452-91 | |
| | | | | | 5 | | | 91-129 456-91 |
| | | | | | 10 | | | 91-129 541-91 |
| 280-1-120 144 | 40 | 22,0 | 15 | 0,865 | 80(ml) | 91-027 630-91 | | |
| | | | | | 0,25 | | 91-129 916-91 | |
| | | | | | 1 | | 91-129 917-91 | |
| | | | | | 5 | | | 91-129 919-91 |
| | | | | | 10 | | | 91-129 920-91 |
| 280-1-120 217 | | | 21 | 0,810 | 80(ml) | | | |
| | | | | | 0,25 | | | |
| | | | | | 1 | | 91-129 941-91 | |
| | | | | | 5 | | | |
| | | | | | 10 | | | |

| Fett Grease Graisse Grasa | Penetration Penetration * Pénétration Penetración | Tropfpunkt Drip-point Point de suintement Punto de goteo | Bestellnummer für Behälter mit: Part number for can with: Numéro de commande pour récipients avec: Número de pedido para recipientes con: | | | |
|------------------------------------|--|---|--|---------------|---------------|--|
| | | | mm/10 | °C | kg |  |
| 280-1-120 205 | | | 0,5 | | | |
| | | | 1 | | | 280-1-120 205 |
| 280-1-120 243 | 375-405 | 150 | 0,5 | 280-1-120 243 | | |
| | | | 1 | | | |
| 280-1-120 247 | 220-250 | 185 | 0,5 | | | |
| | | | 1 | | 280-1-120 247 | |

- N** Stichlänge 6,0 mm.
Stitch length 6,0 mm.
Longueur du point 6,0 mm.
Largo de puntada 6,0 mm.
- N8** Stichlänge 8,0 mm.
Stitch length 8,0 mm.
Longueur du point 8,0 mm.
Largo de puntada 8,0 mm.
- P** Teile zum Hüpftransport.
Components of four-motion drop feed.
Pièces de l'entraînement par griffe sautillante.
Piezas del transportador inferior a cuatro tiempos.
- Unterklassenabhängig, Teilenummer siehe Unterklassen-Ausstattung.
Subclas-dependent, for part number see subclass parts listing.
Fonction de la sous-classe; pour le numéro de la pièce, voir "Équipement de sous-classes".
Dependientes de la subclase, para el número de pieza véase "Dotación de subclases".
- 0** Unterklassenabhängig, Teilenummer siehe Unterklassen-Ausstattung.
For subclass see subclass parts listing.
Appartenance de sous-classe, voir "Équipement de sous-classes".
Para saber a qué subclase pertenece véase "Dotación de subclases".
- 3** Geklebt
Part cemented
Pièce collée
Pieza pegada
- 6** Nadeldicke und Spitzenform bei Bestellung angeben.
Needle size and style of point to be stated on order.
Préciser la grosseur de l'aiguille et la forme de la pointe à la commande.
Grosor de aguja y forma de la punta, indíquese en los pedidos. .
- 22** Zubehör
Accessories
Accessoires
Accesorios
- 27/2** Eingeklammerte Zahl = Dicke in mm.
Number in brackets = thickness in mm.
Chiffre entre parenthèse = épaisseur en mm.
Cifra entre paréntesis = espesor en mm.
- 27/5** Eingeklammerte Zahl = Länge in mm.
Number in brackets = length in mm.
Chiffre entre parenthèse = longueur in mm..
Cifra entre paréntesis = largura en mm.

- 27/18 Eingeklammerte Zahl = Menge.
Number in brackets = Quantity.
Chiffre entre parenthèses = Quantité.
Cifra entre paréntesis = Cantidad.
- 28 Sonderausführung
Spezial version
Version spéciale
Tipo especial
- 28/6 Sonderausführung, nur in Verbindung mit Distanzscheibe Nr. 91-140 414-05 oder
Nr. 91-140 415-05 (siehe Seite 17, 33)
Special version, only in conjunction with spacing washer No. 91-140 414-05 or
No. 91-140 415-05 (se page 17, 33)
Version spéciale, uniquement en liaison avec la rondelle intercalaire n° 91-140 414-05
n° 91-140 415-05 (voir page 17, 33)
Tipo especial, sólo en combinación con la arandela distanciadora 91-140 414-05 ó
N° 91-140 415-05 (véase página 17, 33)
- 28/8 Sonderausführung, für leichten Stoffdrückerdruck.
Special version, for light presser bar pressure.
Version spéciale, pour pression légère de la barre de pression.
Tipo especial, para presión ligera del prensatelas.
- 32 Beim Einbau dieses Teiles wird für die Paßgenauigkeit zum Anschlußteil keine Garantie übernommen;
zweckmäßig vollständiges Aggregat bestellen.
No guarantee is assumed that this part will fit the mating part; it is best to order a complete
assembly.
Aucune garantie ne pourra être assurée quant à la précision d'ajustage de cette pièce avec la pièce
correspondante; il est indiqué de commander un mécanisme complet.
Al montar esta pieza no se asume garantía alguna en cuanto a la tolerancia y precisión de ajuste
respecto a la pieza correspondiente; por esta razón se recomienda pedir el grupo completo.
- 35/1 Bei Montage vernieten.
To be riveted after assembly.
River après montage.
Remáchese después del montaje.
- 35/4 Bei Montage bohren und verstopfen.
To be drilled and pinned after assembly.
Percer et goupiller après montage.
Debera bacerse un taladro y colocarse un pasador antes del montaje.
- 40/1 Füllen mit 280-1-120 144, Bestellnummer siehe Seite 5.
Top um with 280-1-120 144; for part number see page 5.
Remplir de 280-1-120 144; n° de commande, voir page 5.
Rellene con 280-1-120 144; para el número de pedido véase la página 5.
- 40/3 Fetten mit 280-1-120 247; Bestellnummer siehe Seite 5.
Grease with 280-1-120 247; for part number see page 5.
Graisser avec de la graisse 280-1-120 247; n° de commande, voir page 5.
Engrase con grasa 280-1-120 247; para el número de pedido véase la página 5.

40/4 Fetten mit 280-1-120 243; Bestellnummer siehe Seite 5.
Grease with 280-1-120 243; for part number see page 5.
Graisser avec de la graisse 280-1-120 243; n° de commande, voir page 5.
Engrase con grasa 280-1-120 243 para el número de pedido véase la página 5.

40/6 Füllen mit 280-1-120 217, Bestellnummer siehe Seite 5.
Top um with 280-1-120 217; for part number see page 5.
Remplir de 280-1-120 217; n° de commande, voir page 5.
Rellene con 280-1-120 217; para el número de pedido véase la página 5.

40/7 Tränken mit 280-1-120 217, Bestellnummer siehe Seite 5.
Soak with 280-1-120 217, for part number see page 5.
Imbiber d'huile 280-1-120 217; n° de commande, voir page 5.
Empape con aceite 280-1-120 217; para el N° de pedido véase la página 5.

40/8 Tränken mit 280-1-120 122, Bestellnummer siehe Seite 5.
Soak with 280-1-120 122, for part number see page 5.
Imbiber d'huile 280-1-120 122; n° de commande, voir page 5.
Empape con aceite 280-1-120 122; para el N° de pedido véase la página 5.

40/13 Fetten mit 280-1-120 205; Bestellnummer siehe Seite 5.
Grease with 280-1-120 205; for part number see page 5.
Graisser avec de la graisse 280-1-120 205; n° de commande, voir page 5.
Engrase con grasa 280-1-120 205 para el número de pedido véase la página 5.

40/15 Zum Schmiernippel Nr. 15-711 050-51 (siehe Seite 11, 21)
For grease nipple No. 15-711 050-51 (see pages 11, 21)
Pour le graisseur n° 15-711 050-51 (voir pages 11, 21)
Para el engrasador N° 15-711 050-51 (véanse las páginas 11, 21)

81/1 Stückzahl je nach Bedarf.
Quantity as required.
Nombre en fonction besoin.
Cantidad según sea necesario.

81/3 Verwendung je nach Bedarf.
To be used as required.
Utilisation en fonction du besoin.
Utilización, según sea necesario.

90/1 Für Wechselstrom.
For single-phase A.C.
Pour du courant alternatif.
Para corriente alterna monofásica.

90/2 Für Drehstrom.
For three-phase A.C.
Pour du courant triphasé.
Para corriente trifásica.

- 90/3 Zur Motorbefestigung
For fitting the motor.
Pour la fixation du moteur.
Para fijación del motor.
- 90/9 Für Motoren mit 8-stelliger Typennummer.
For motors with 8-digit model number.
Pour moteurs avec numéro de modèle à 8 chiffres.
Para motores con número de modelo de 8 cifras.
- 90/11 Für Elektronik-Stop-Motoren.
For electronic Stop motors.
Pour moteurs Stop électroniques.
Para motores stop electrónicos.
- 90/17 Für Maschinen ohne Stop-Motor.
For machines without Stop motor.
Pour machines sans moteur Stop.
Para máquinas sin motor stop.
- 90/18 Für Maschinen mit Stop-Motor.
For machines with Stop motor.
Pour machines avec moteur Stop.
Para máquinas con motor stop.
- 90/47 Nr. 91-141 572-12 mitbestellen.
Include No. 91-141 572-12 in your order.
Comprendre la pièce n° 91-141 572-12 dans votre commande.
Pidase juntamente el Nº 91-141 572-12.
- 95/4 x-Wert = Stichlänge, bei Bestellung angeben.
x-value = stitch length, to be stated on order.
Valeur "x" = longueur du point, à préciser à la commande.
Valor x = largo de puntada, indiquese en los pedidos.
- 96 Länge angeben.
State length.
Préciser longueur.
Indiquese la largura.
- 96/4 Schlauch mit 4 mm Innendurchmesser, bei Bestellung Länge angeben.
Tube with 4 mm inside dia; length to be stated on order.
Flexible d'un diamètre intérieur de 4 mm; préciser la longueur.
Tubo flexible de 4 mm de diamètre interior; indiquese la largura en los pedidos.
- 96/6 Schlauch mit 6 mm Innendurchmesser, bei Bestellung Länge angeben.
Tube with 6 mm inside dia; length to be stated on order.
Flexible d'un diamètre intérieur de 6 mm; préciser la longueur.
Tubo flexible de 6 mm de diamètre interior; indiquese la largura en los pedidos.

1

Pièces de tête Piezas de la cabeza PFAFF 1245-706/07 CN; CN 8

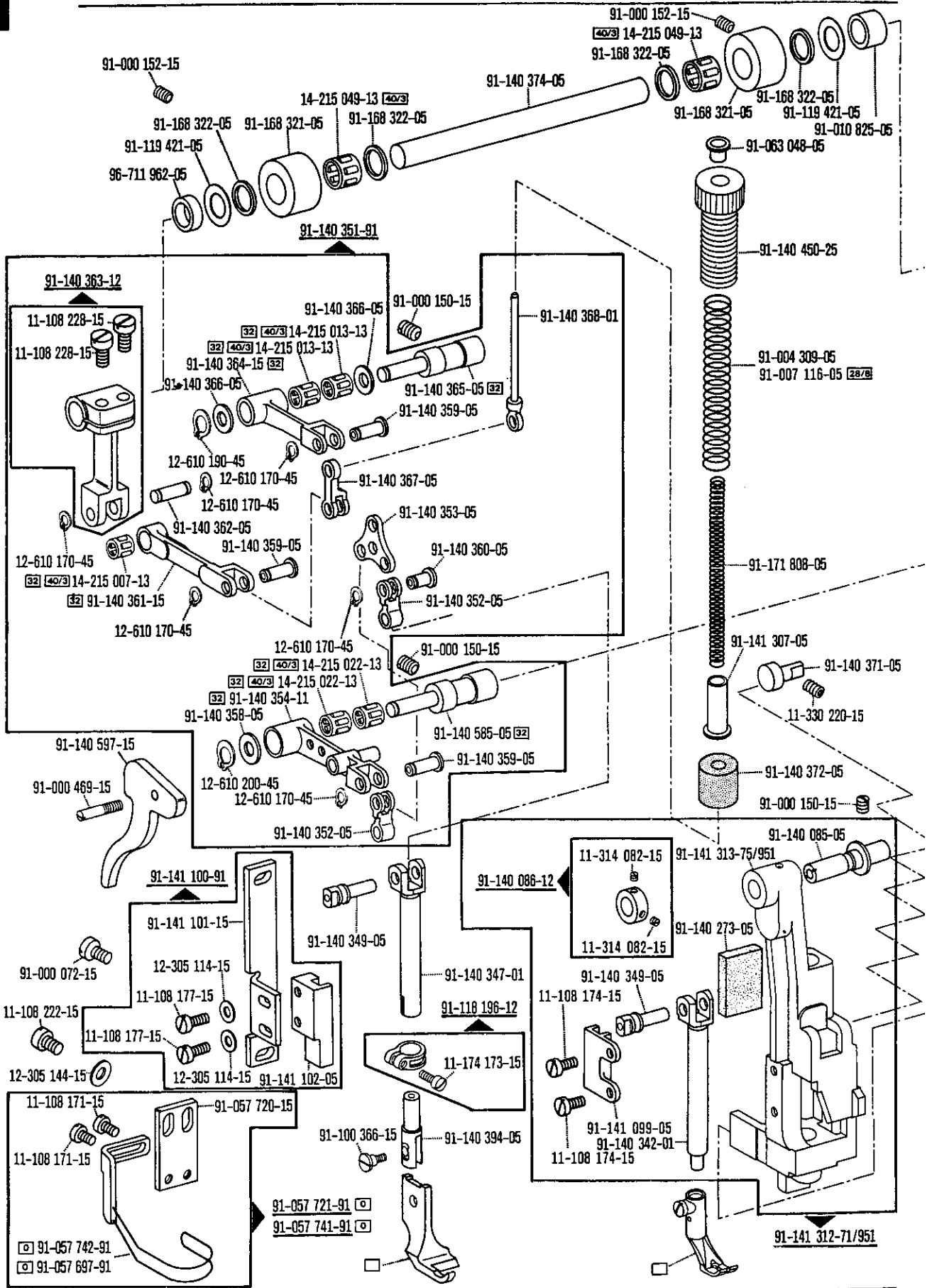

Pièces de tête
 Piezas de la cabeza PFAFF 1245-706/07 CN; CN 8

1

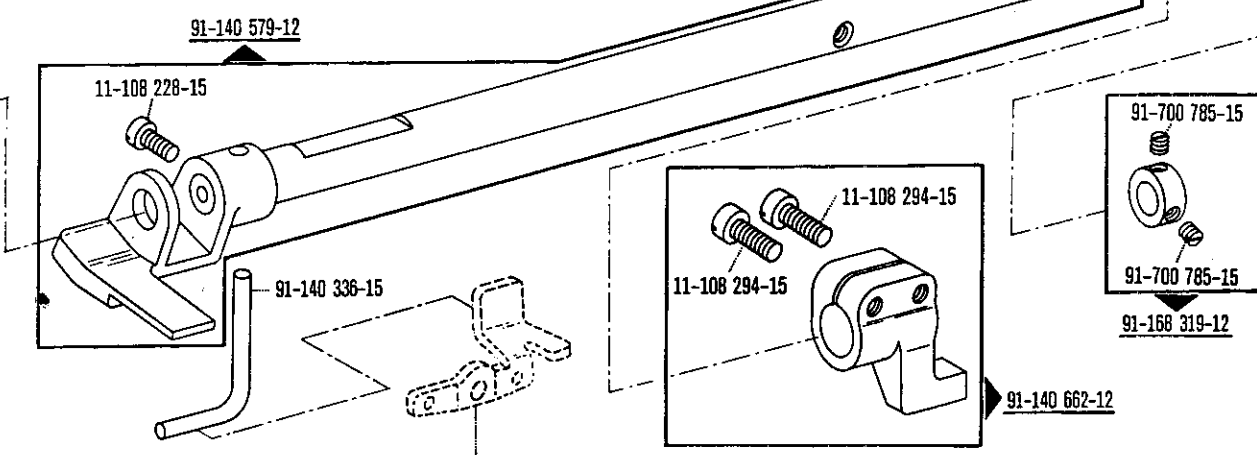
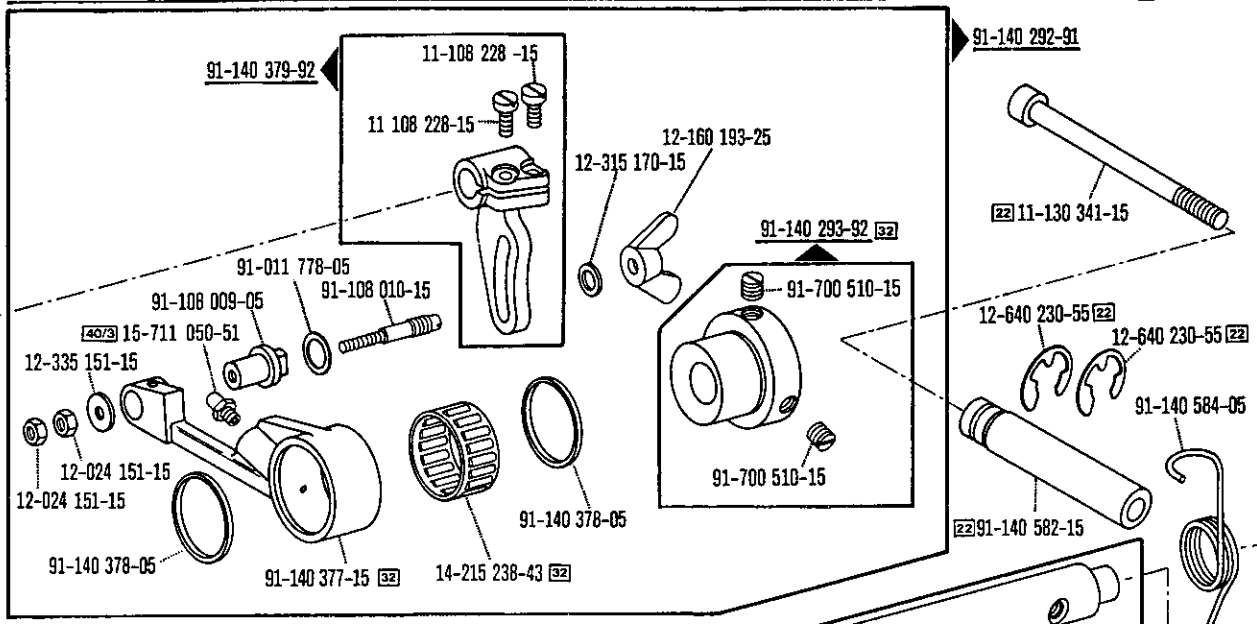

siehe Seite 12
 see page 12
 voir page 12
 véase la página 12

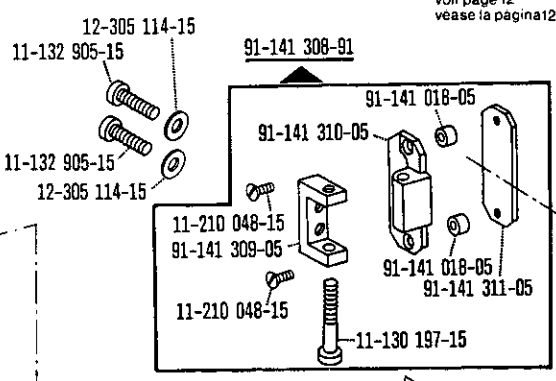

System 134-35
 Système 134-35
 Sistema 134-35

91-140 679-92 (-6/07)

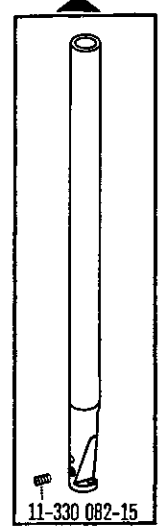

91-140 071-91

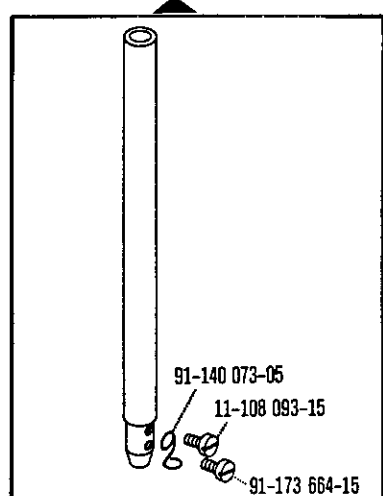

☐ siehe Erläuterungen Register 0
 see explanations in section 0
 voir légende registre 0

1

Needle head parts
Pièces de tête
Piezas de la cabeza PFAFF 1245-706/07 CN; CN 8

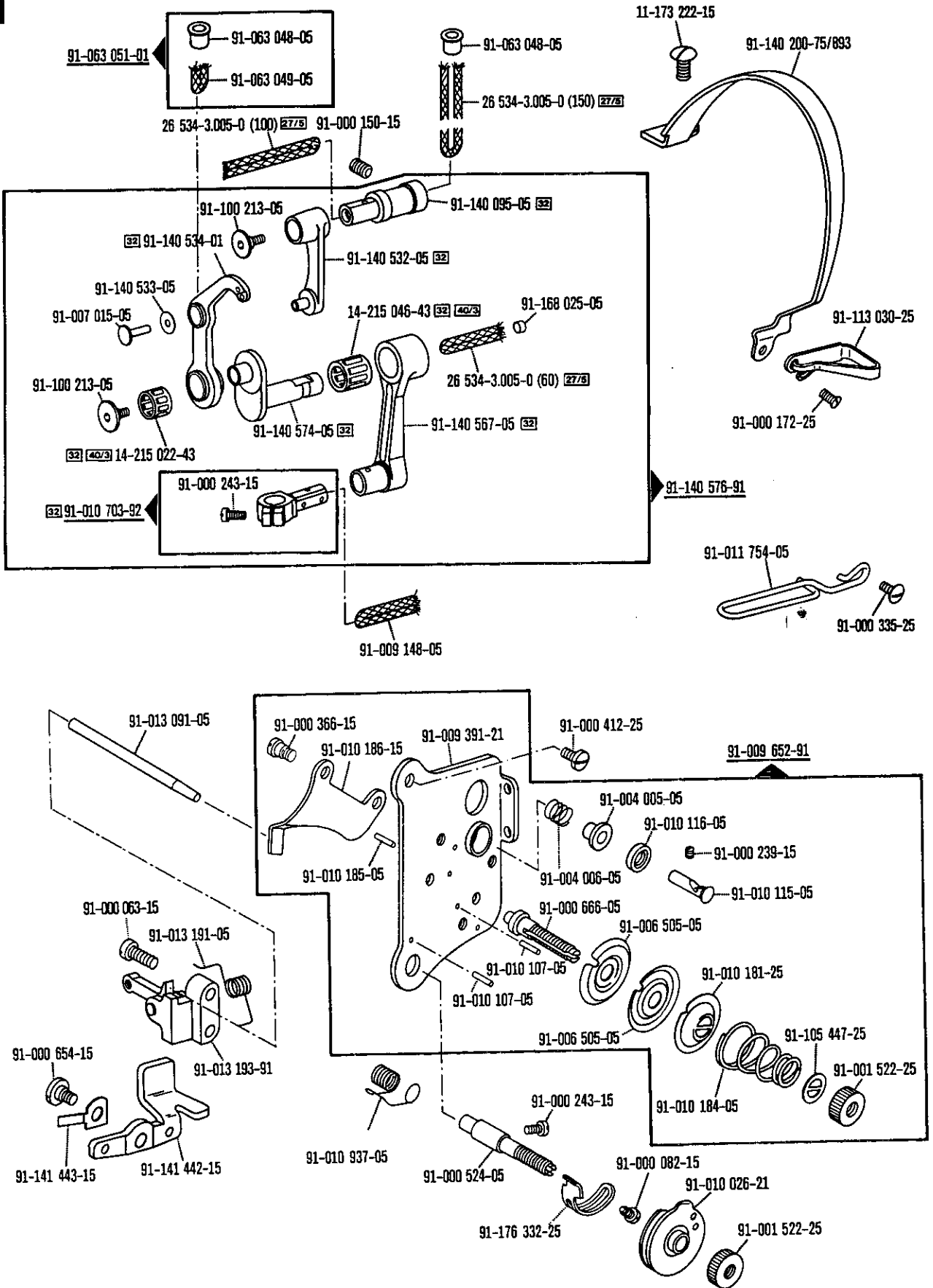

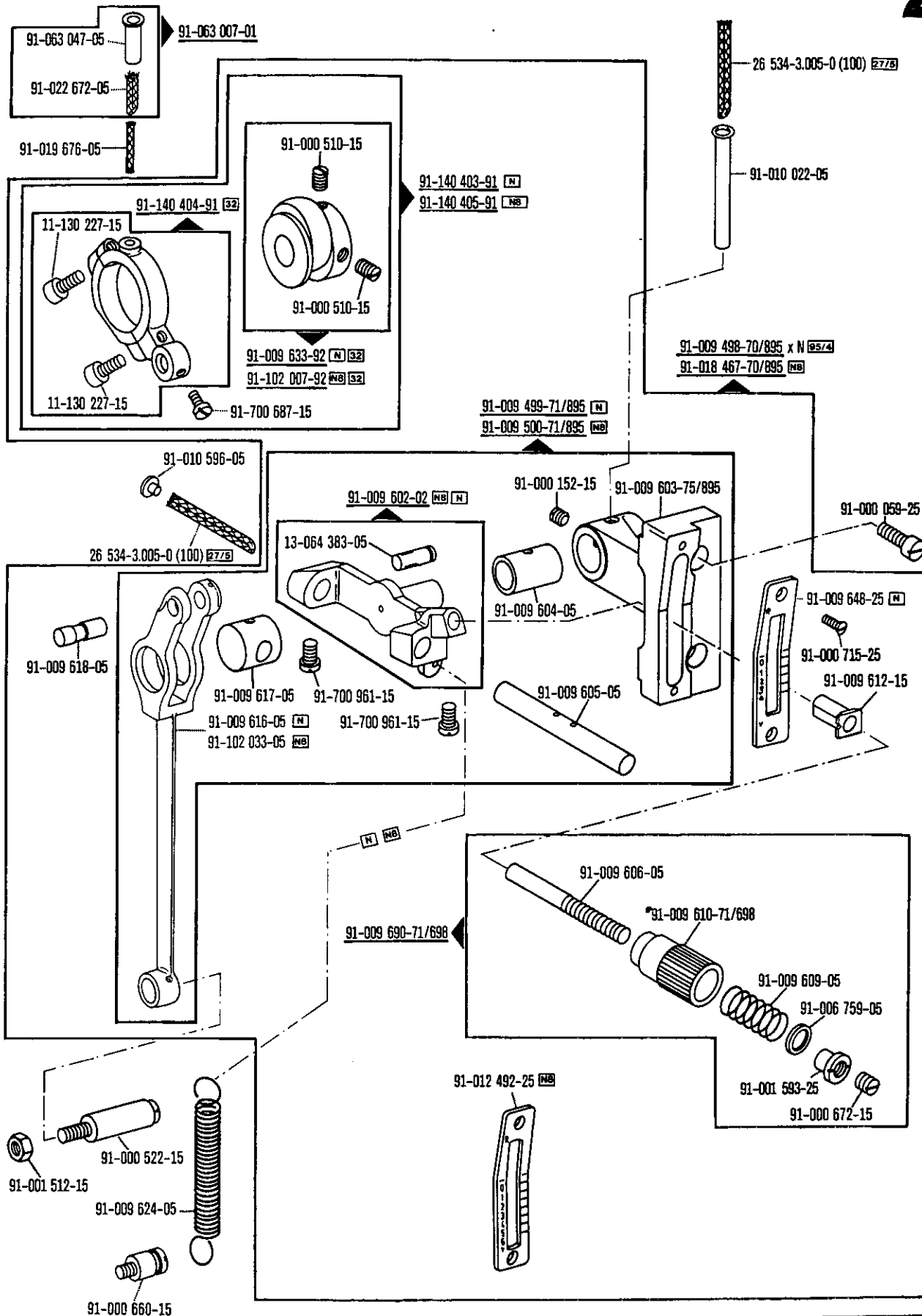

2

Arm parts
Pièces de bras
Piezas del brazo PFAFF 1245-706/07 CN; CN 8

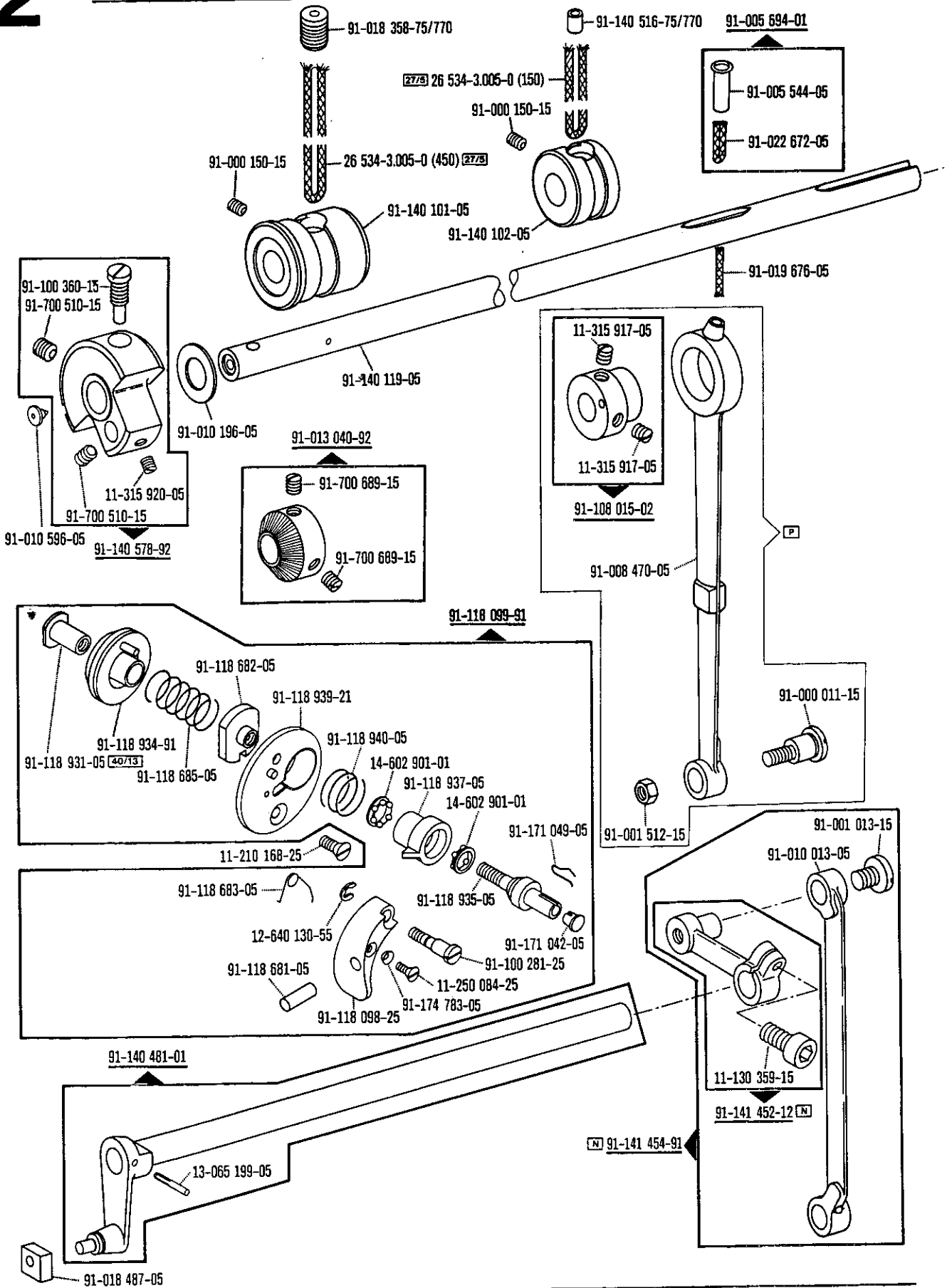

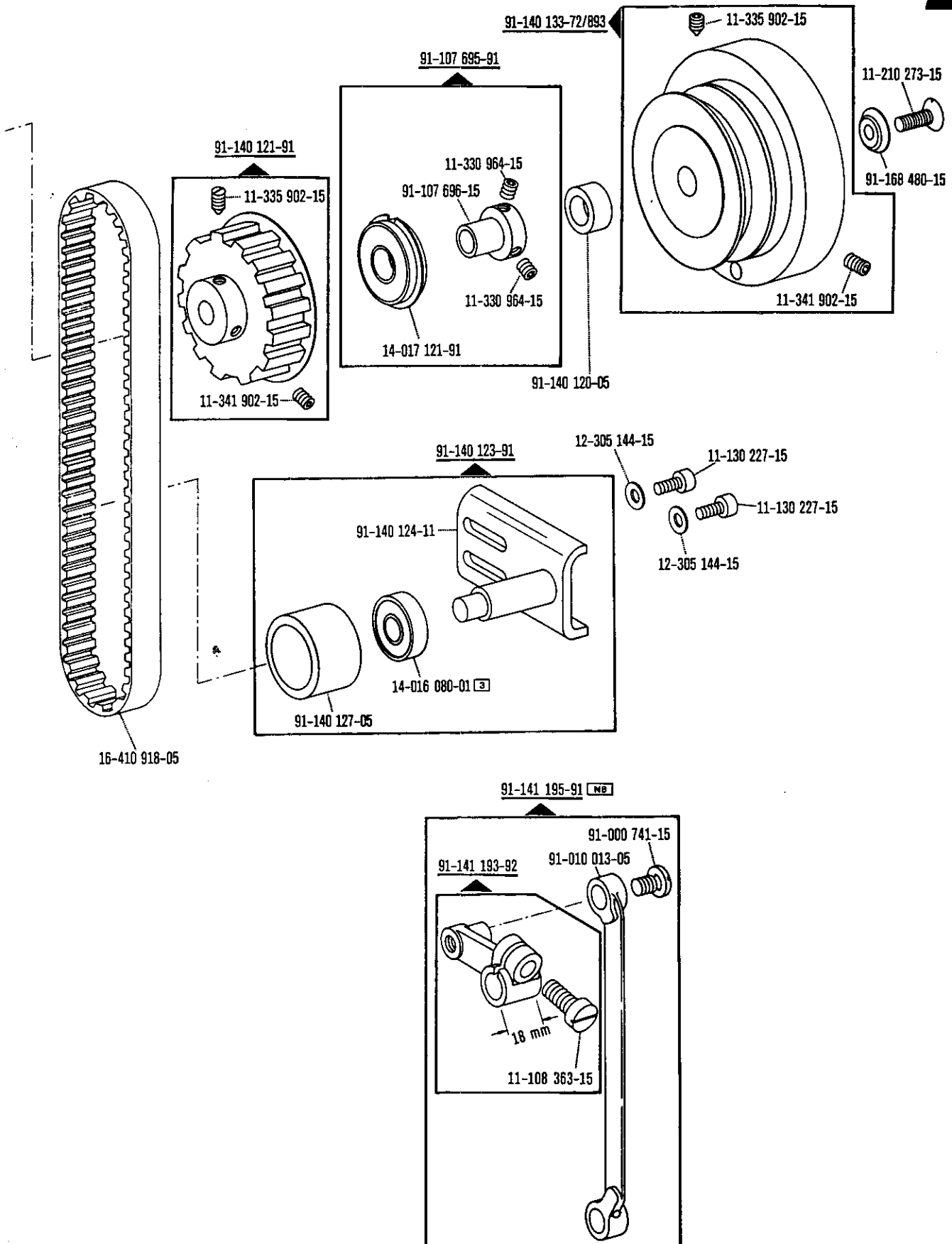

3

Requisite parts
Pièces du plateau fondamental
Piezas de la placa-base

PFAFF 1245-706/07 CN; CN 8

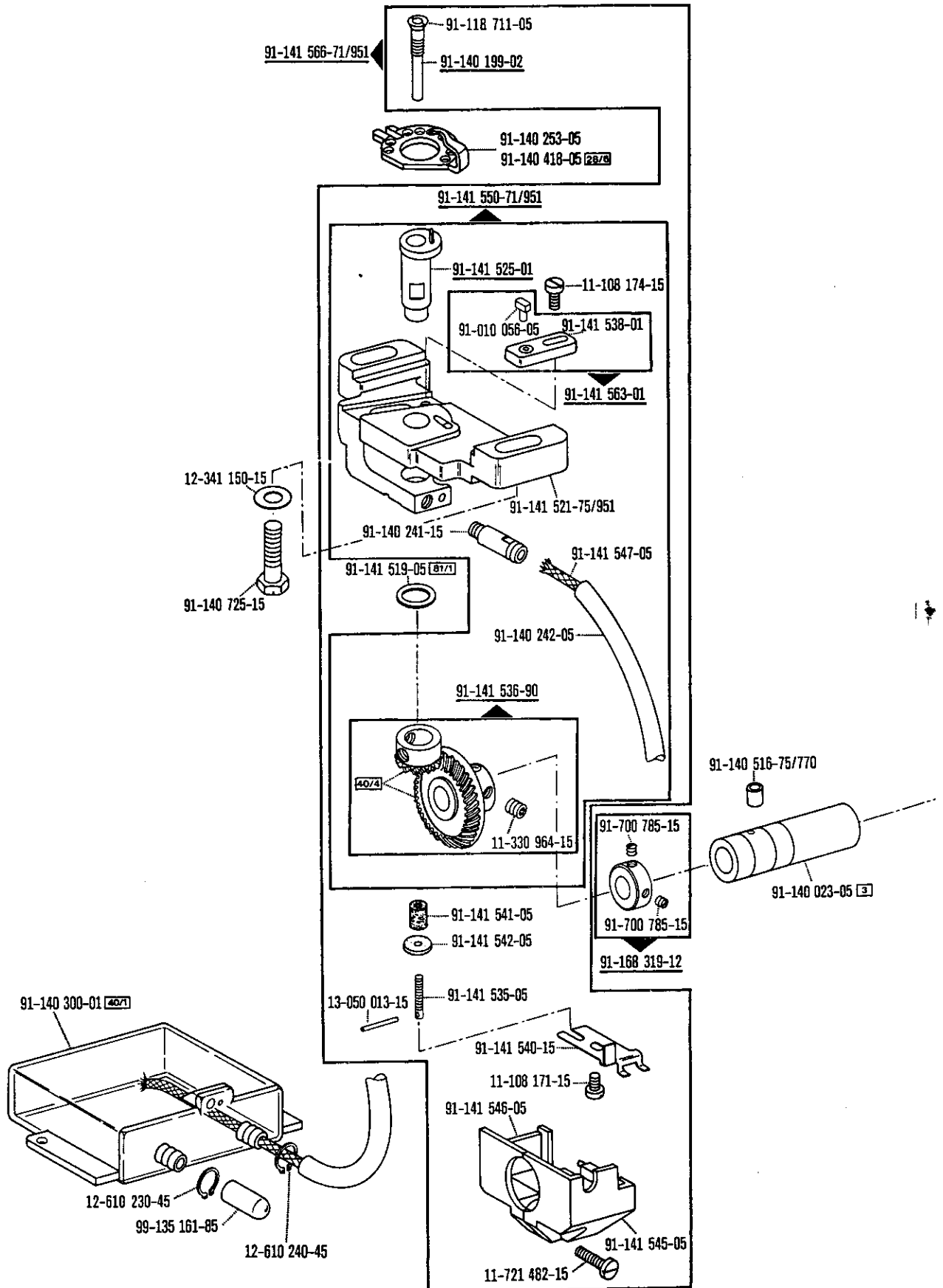

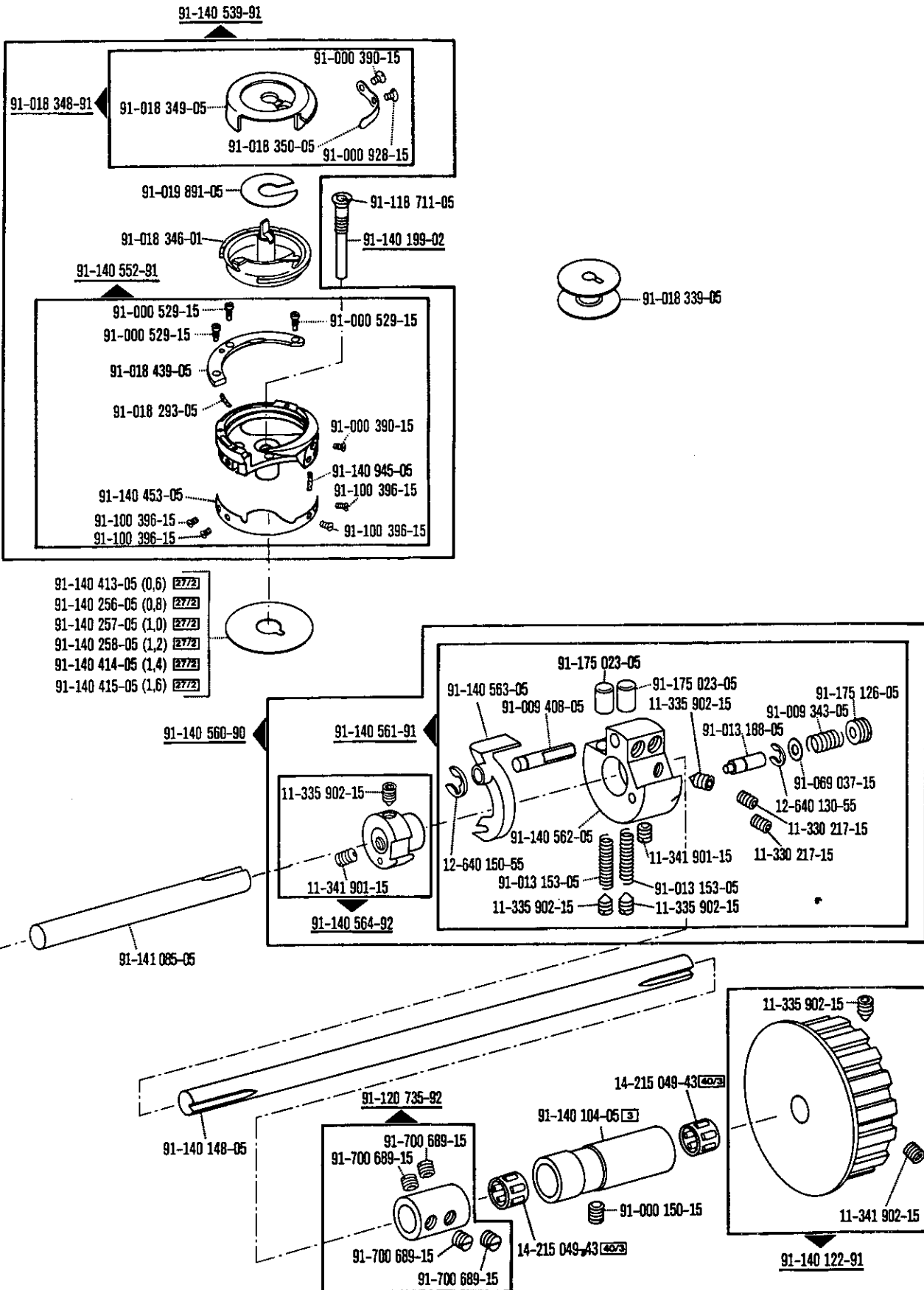

☐ siehe Erläuterungen Register O
see explanations in section O
voir légende registre O

3

Pièces du plateau fondamental Piezas de la placa-base

PFAFF 1245-706/07 CN; CN 8

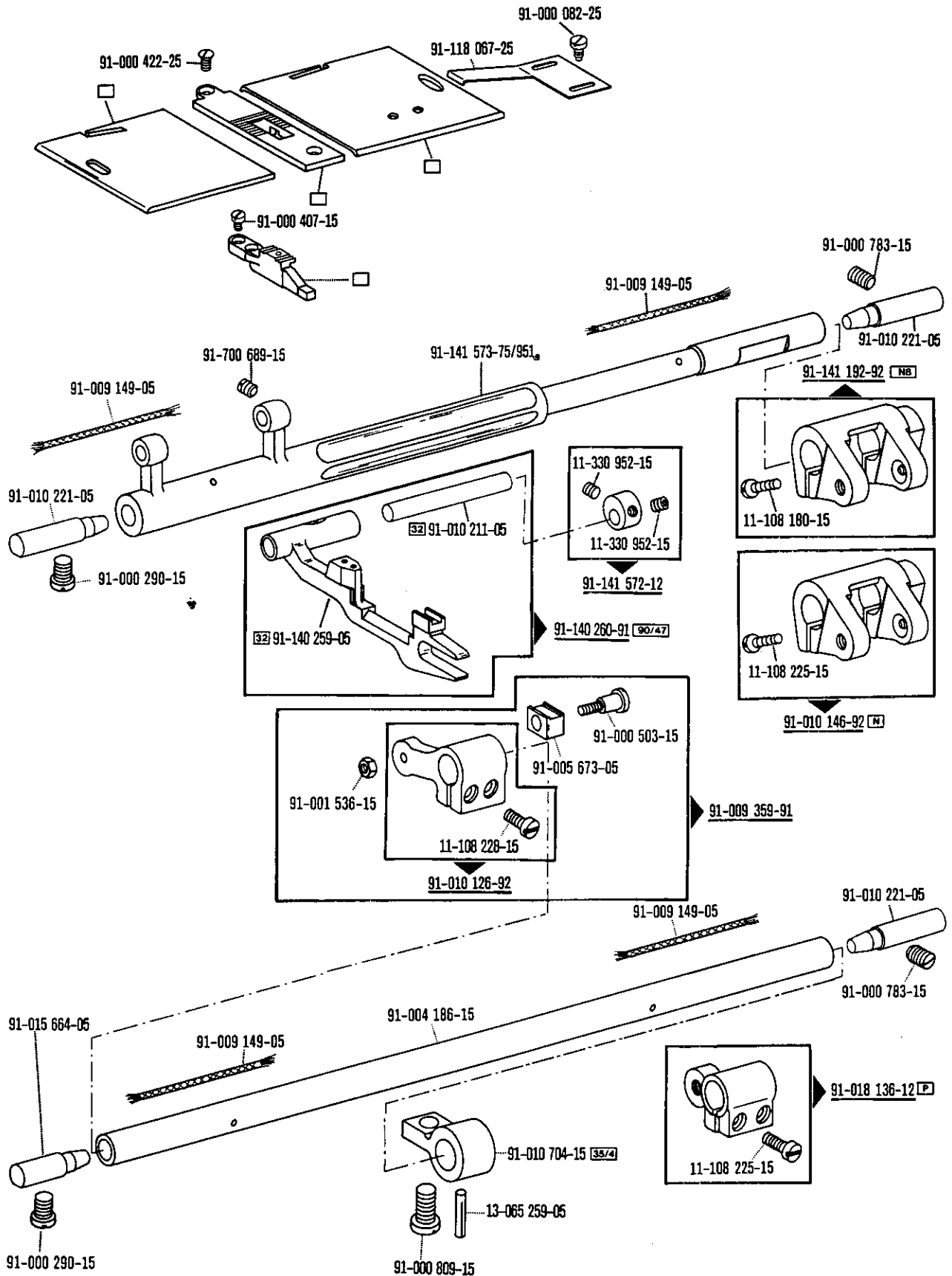

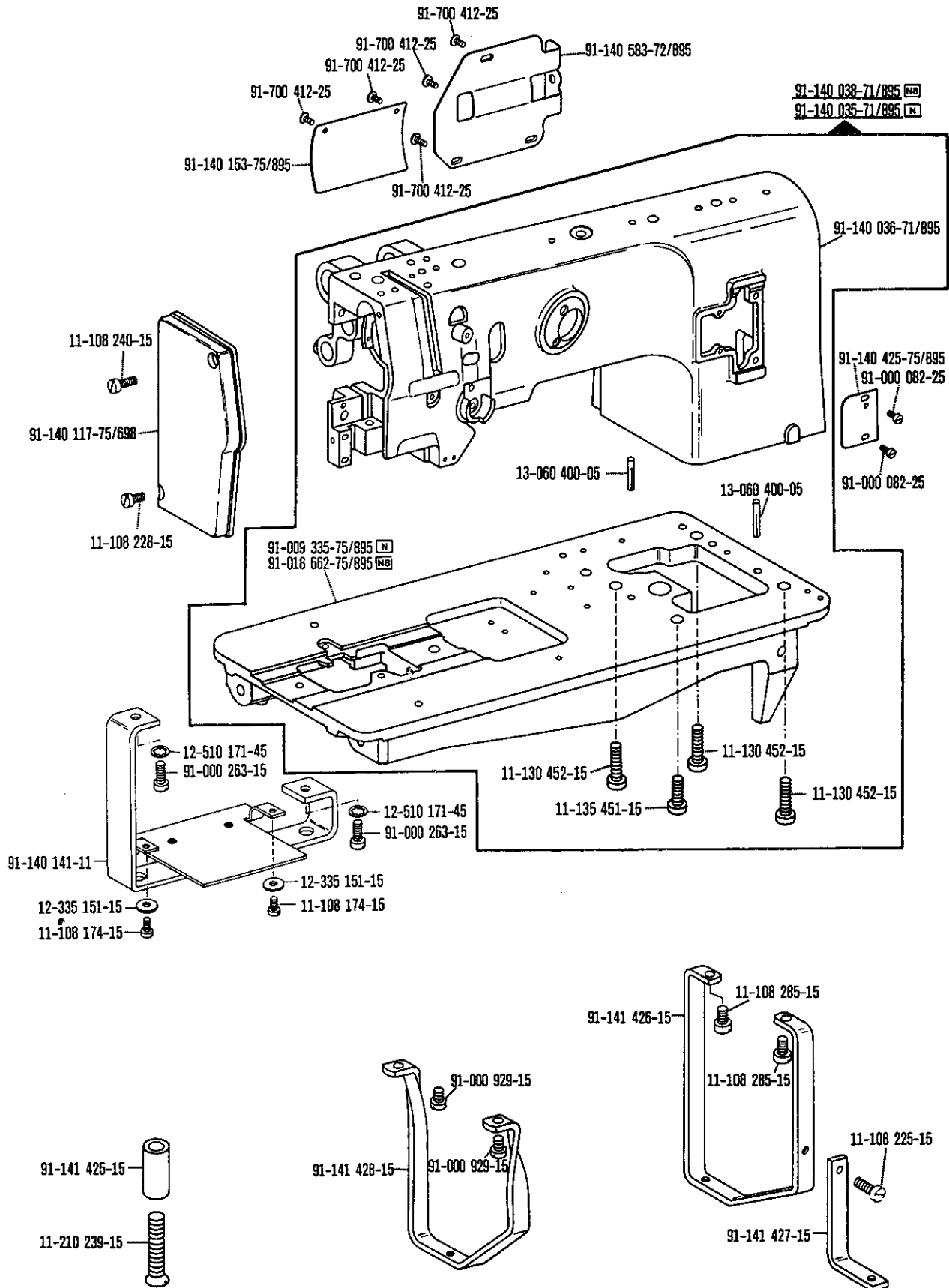

5

Needle head parts
Pièces de tête
Piezas de la cabeza PFAFF 1245-706/47 CN

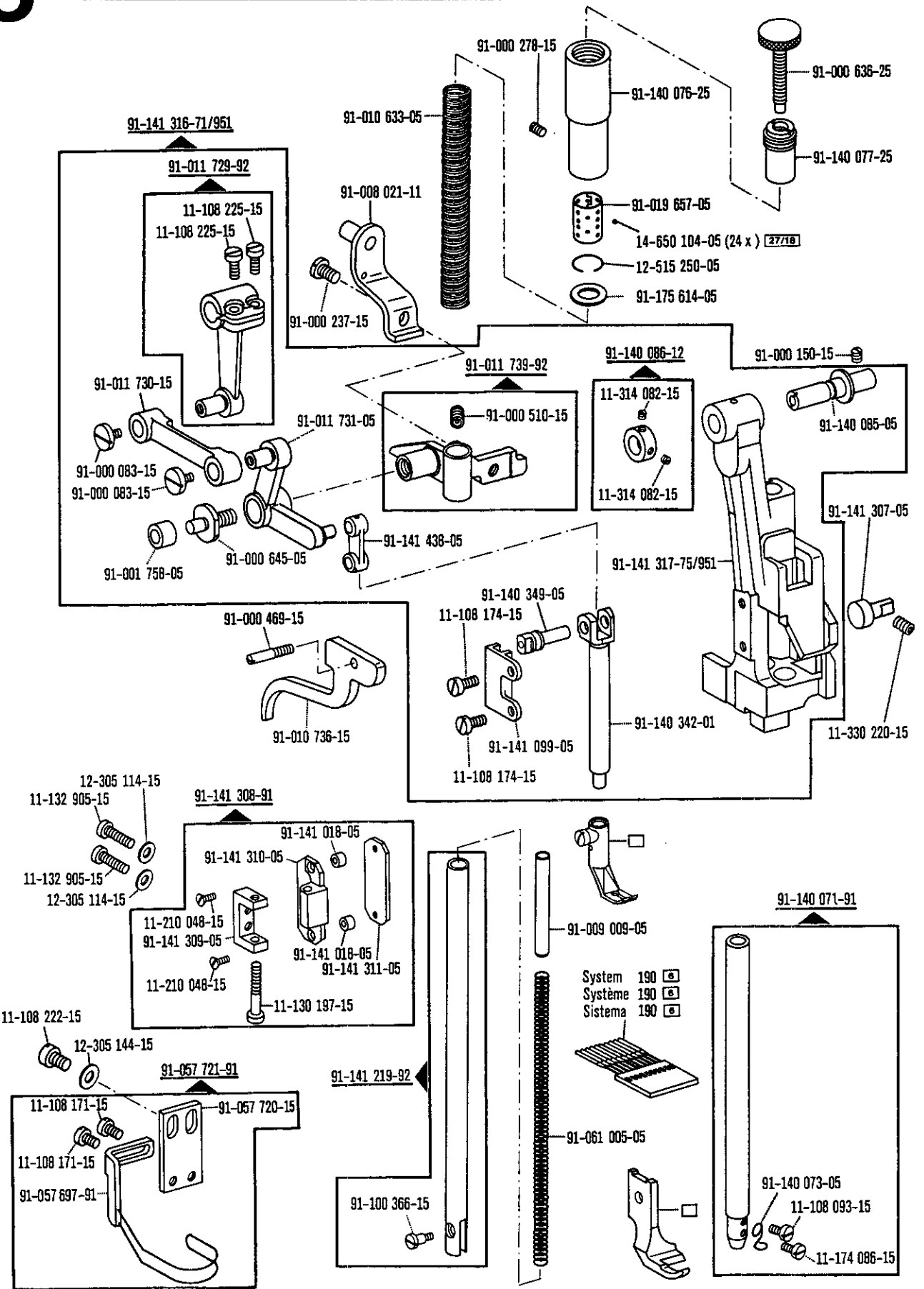

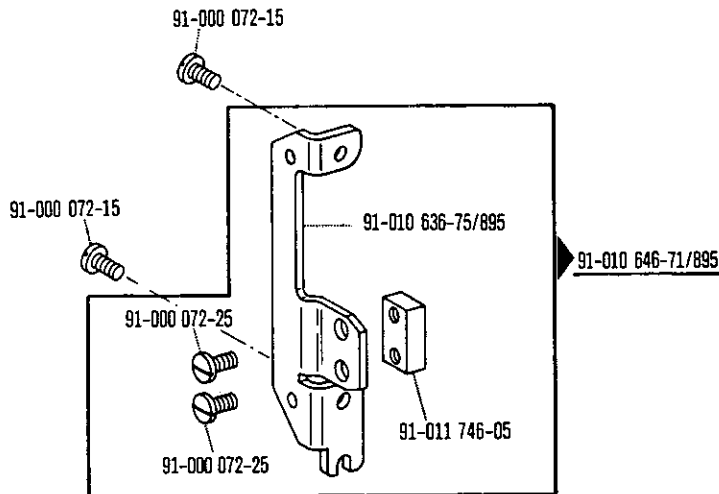
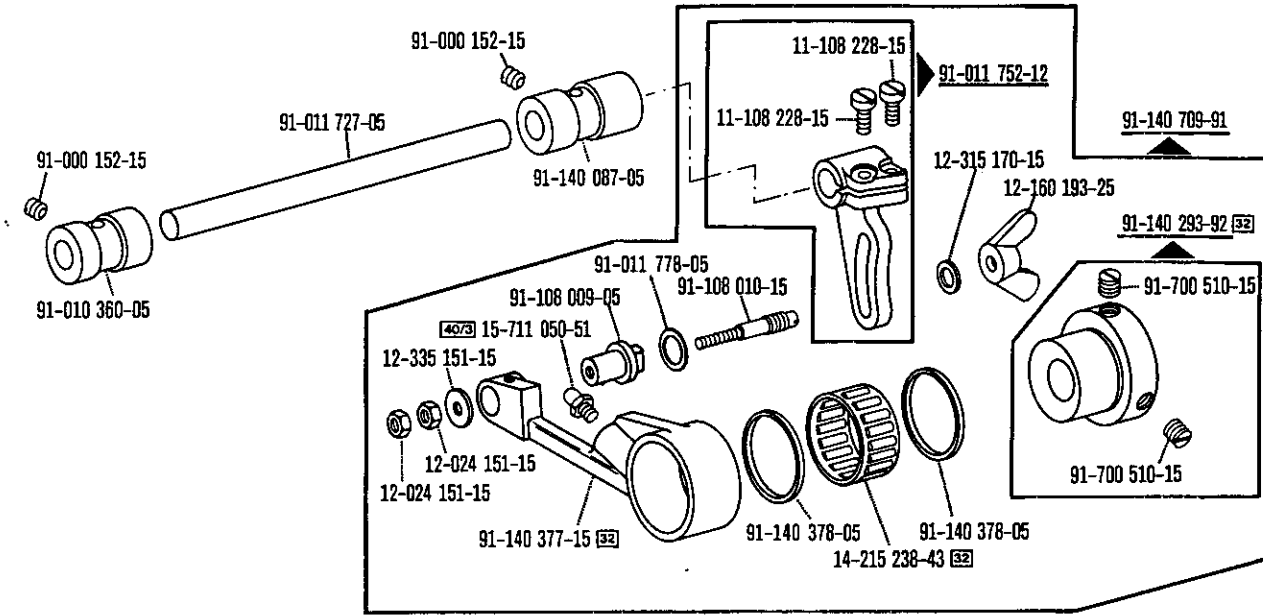

5

Needle head parts
Pièces de tête
Piezas de la cabeza PFAFF 1245-706/47 CN

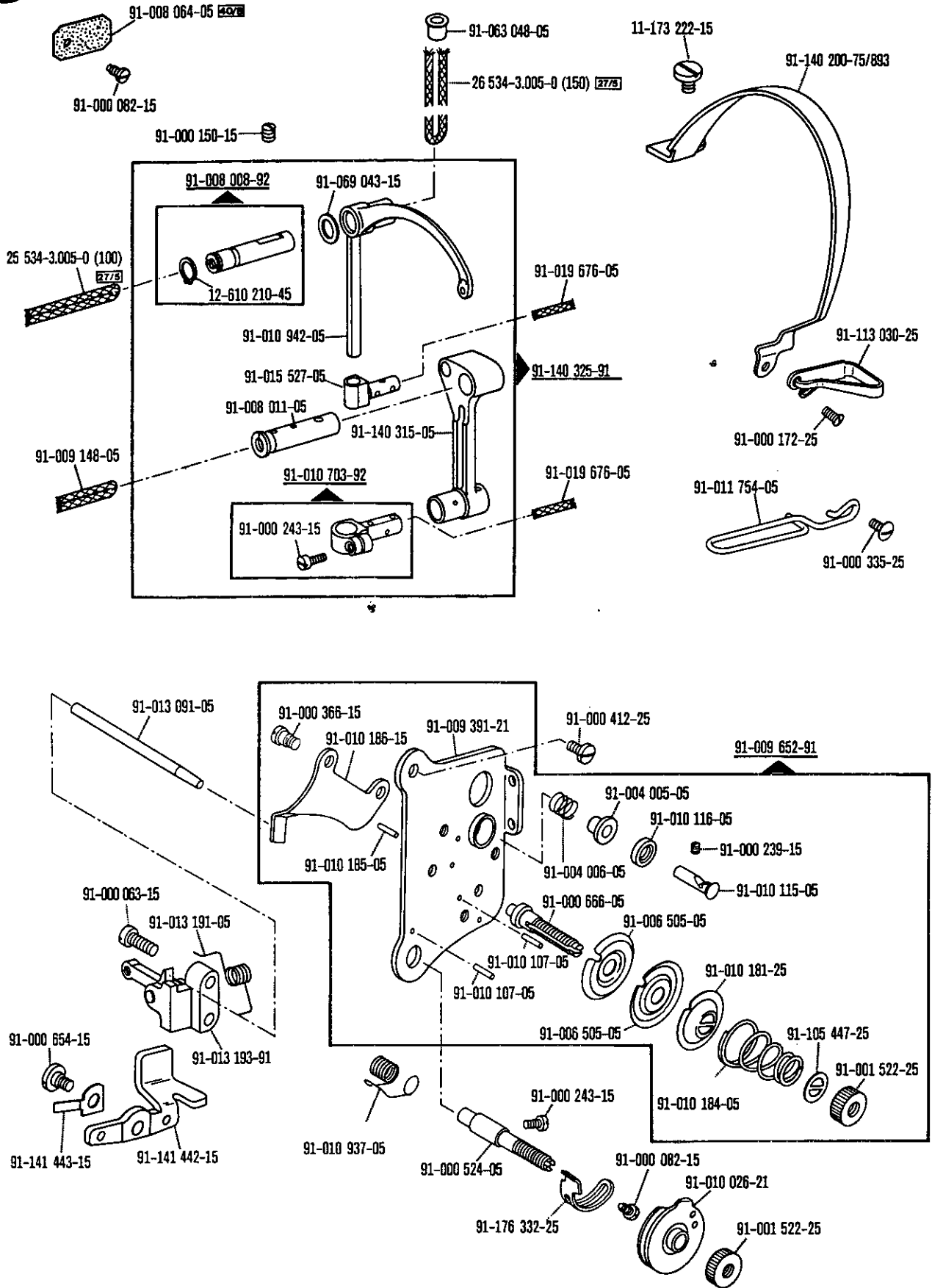

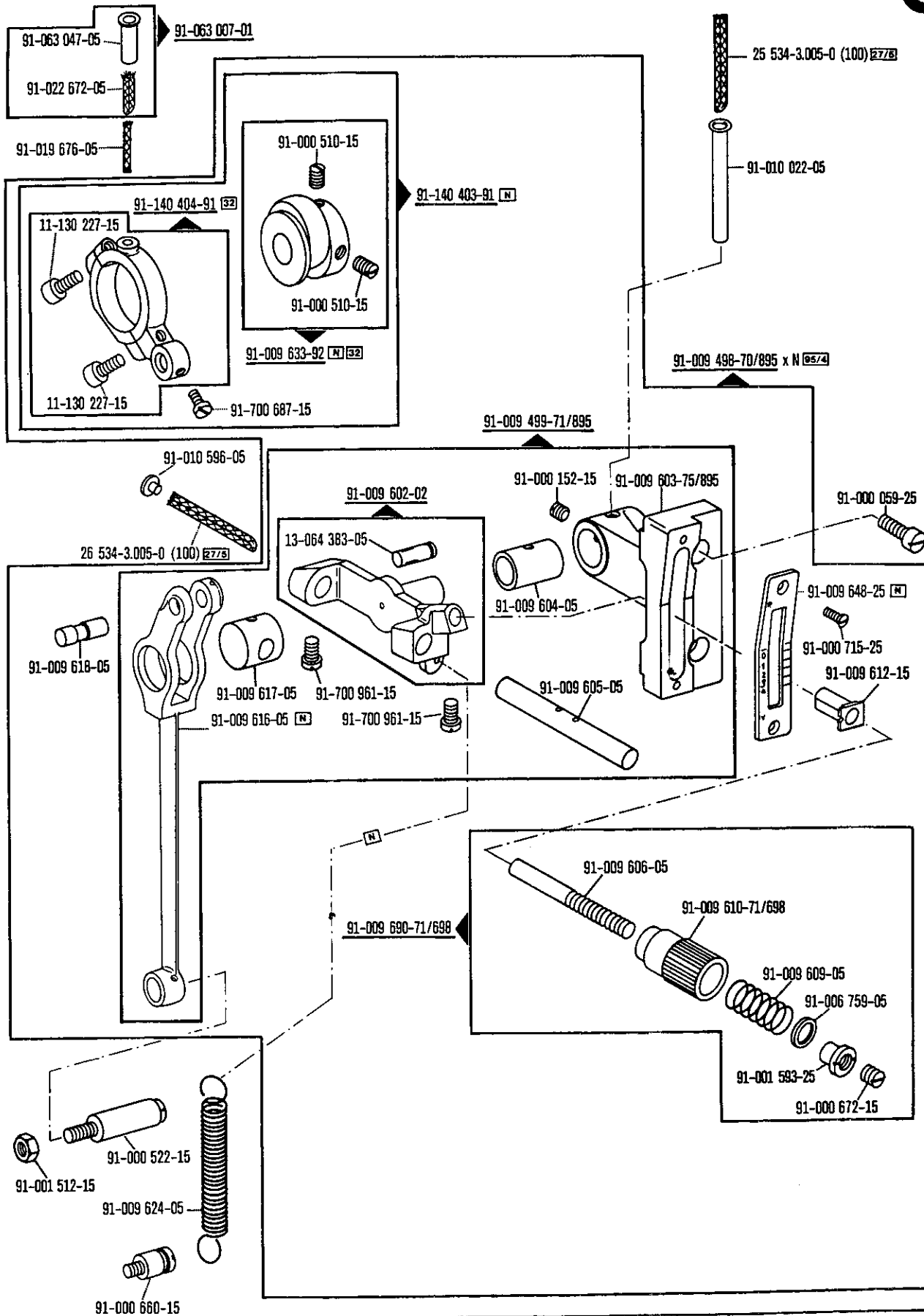

6

Arm parts
Pièces de bras
Piezas del brazo PFAFF 1245-706/47 CN

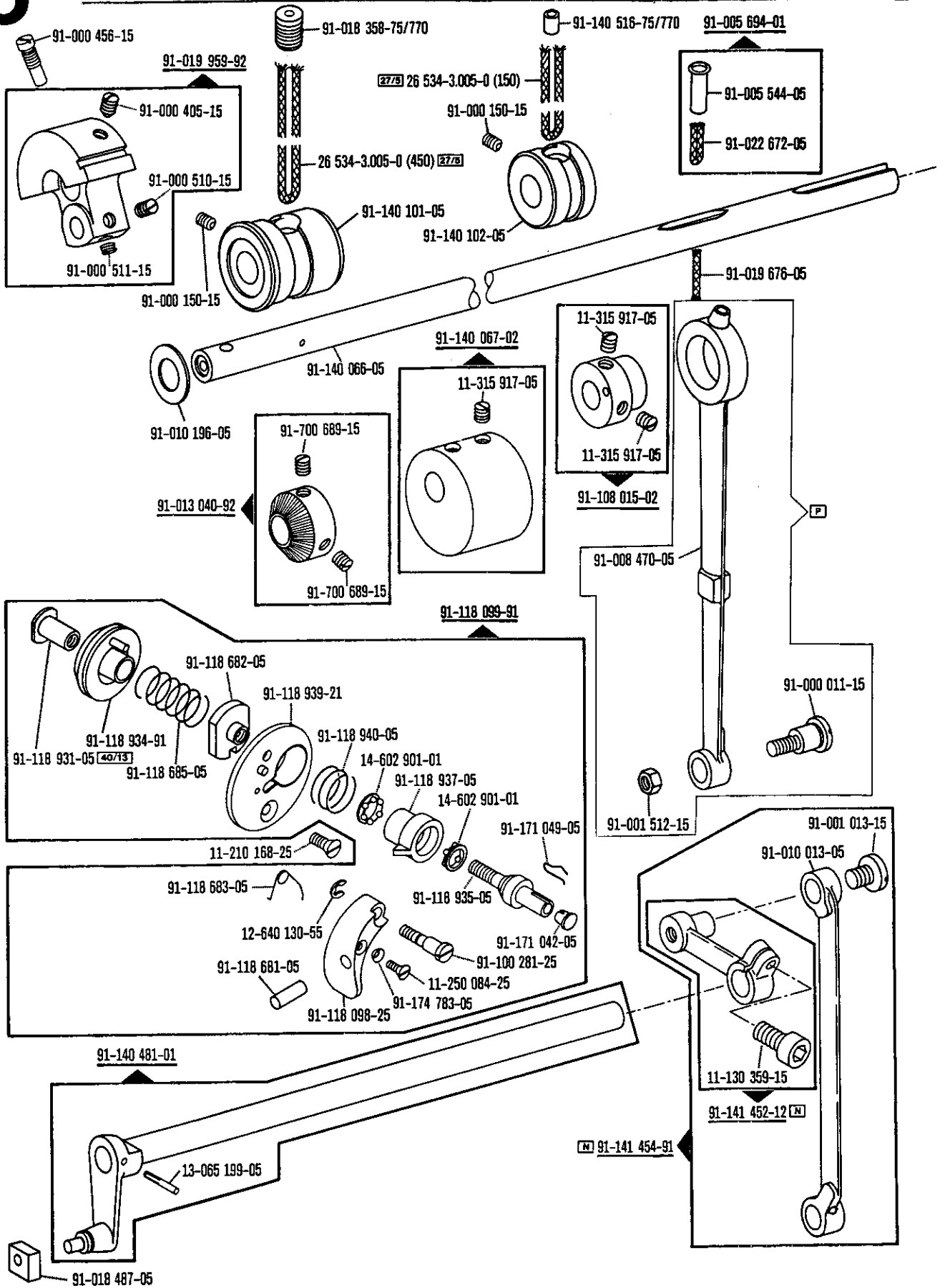

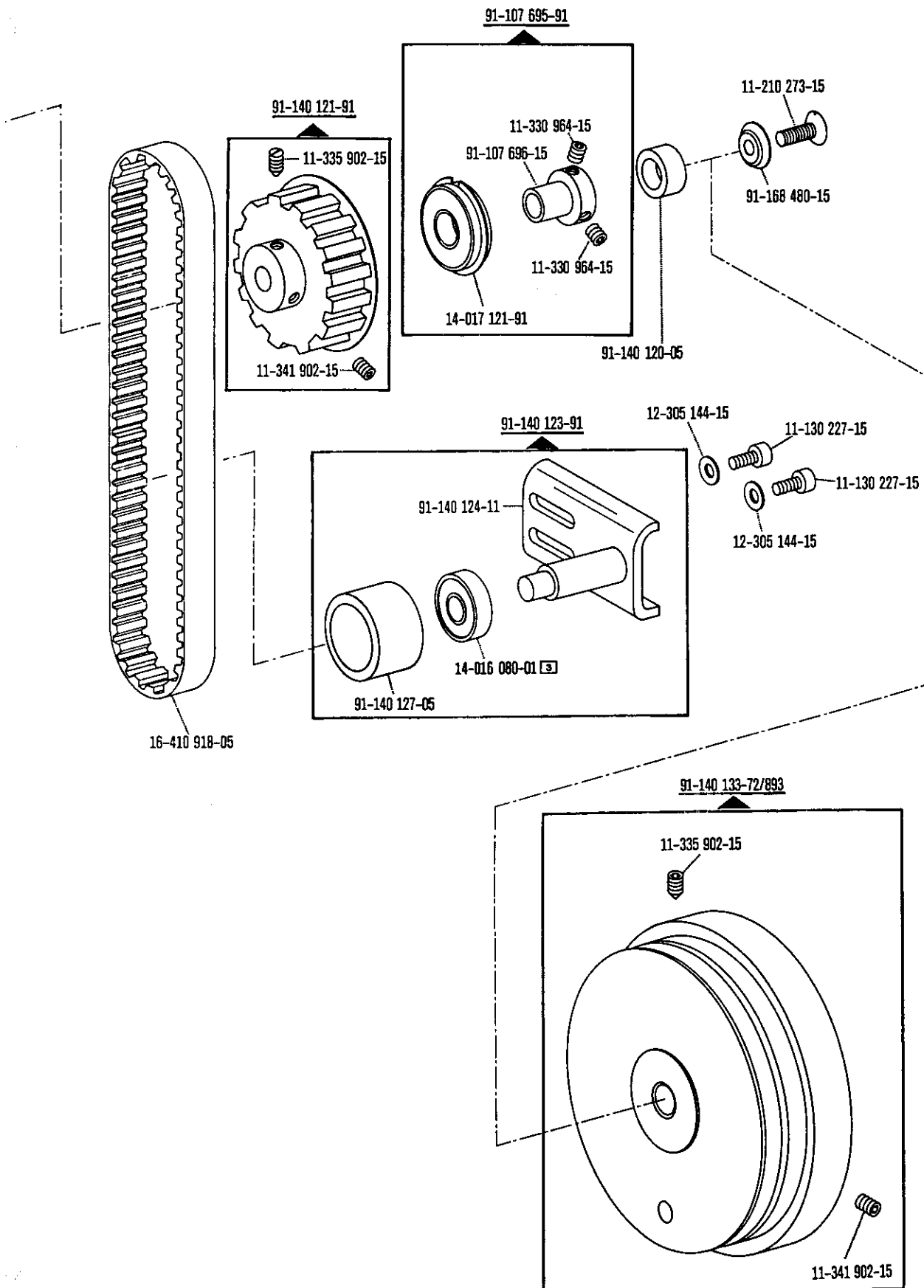

☐ siehe Erläuterungen Register O
 see explanations in section O
 voir légende registre O

6

Arm parts
Pièces de bras
Piezas del brazo PFAFF 1245-706/47 CN

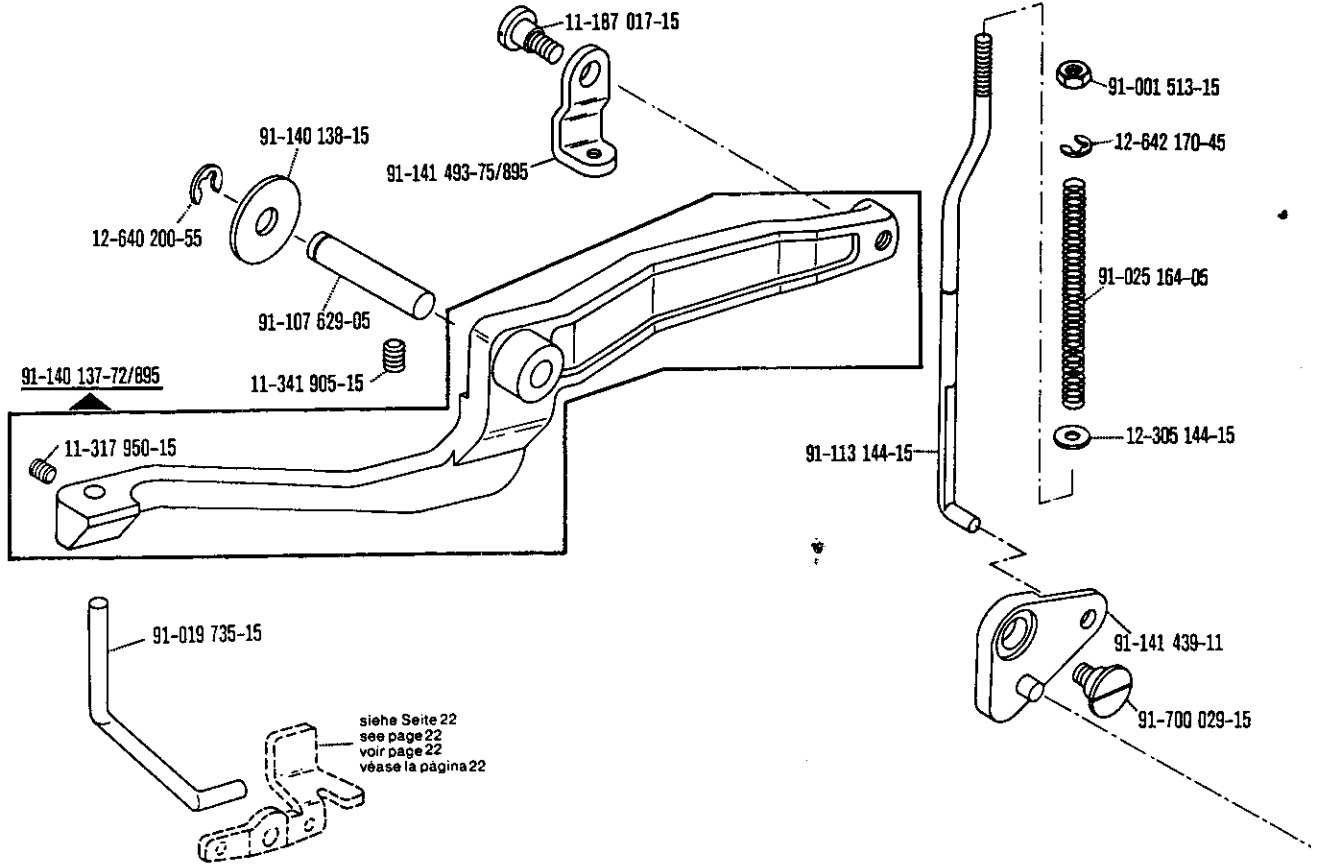

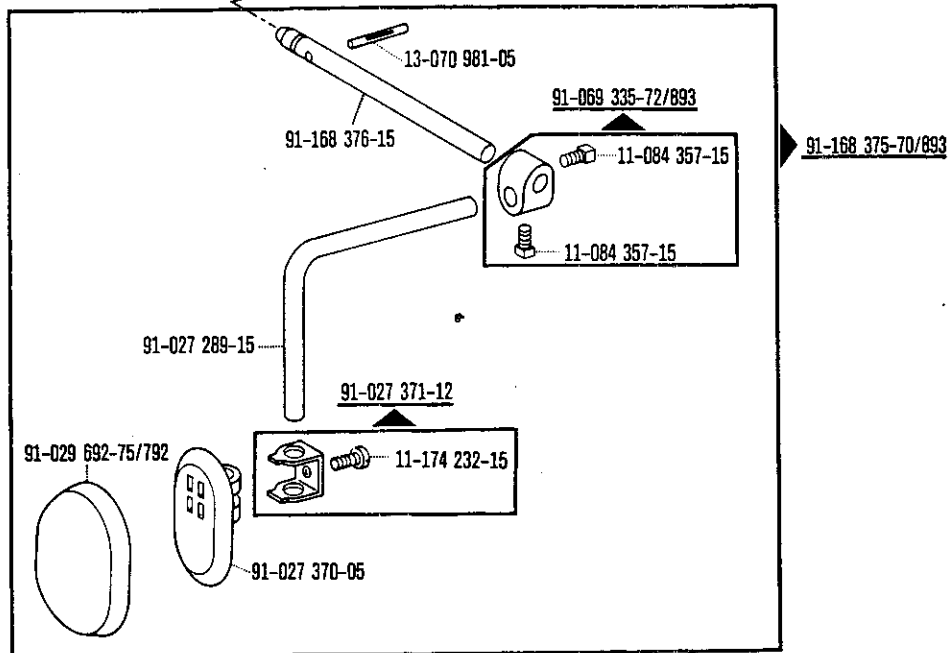
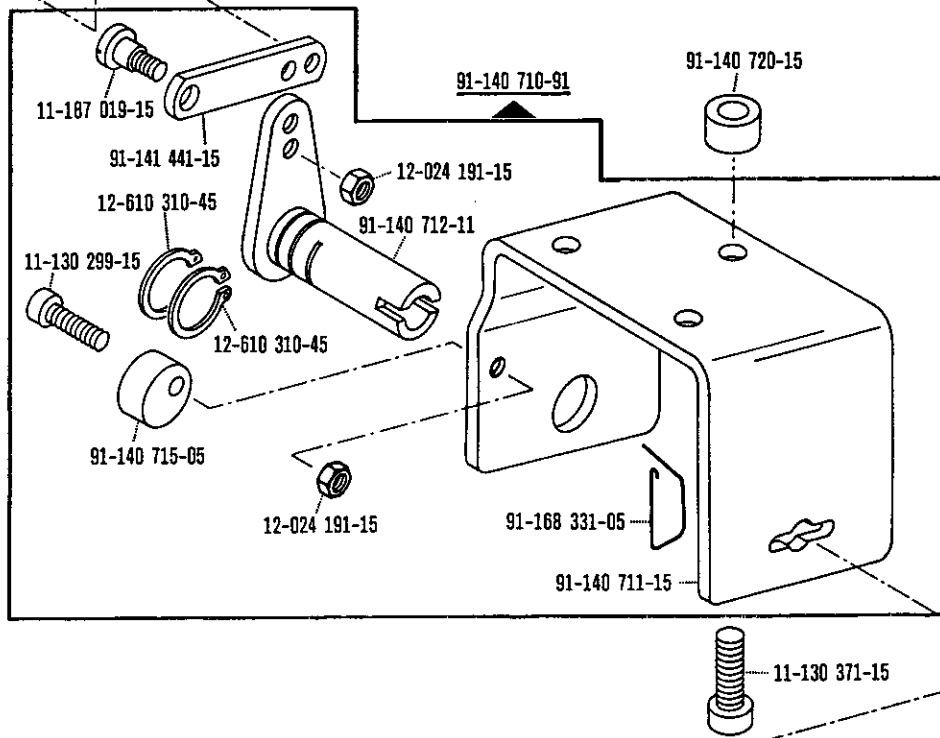

7

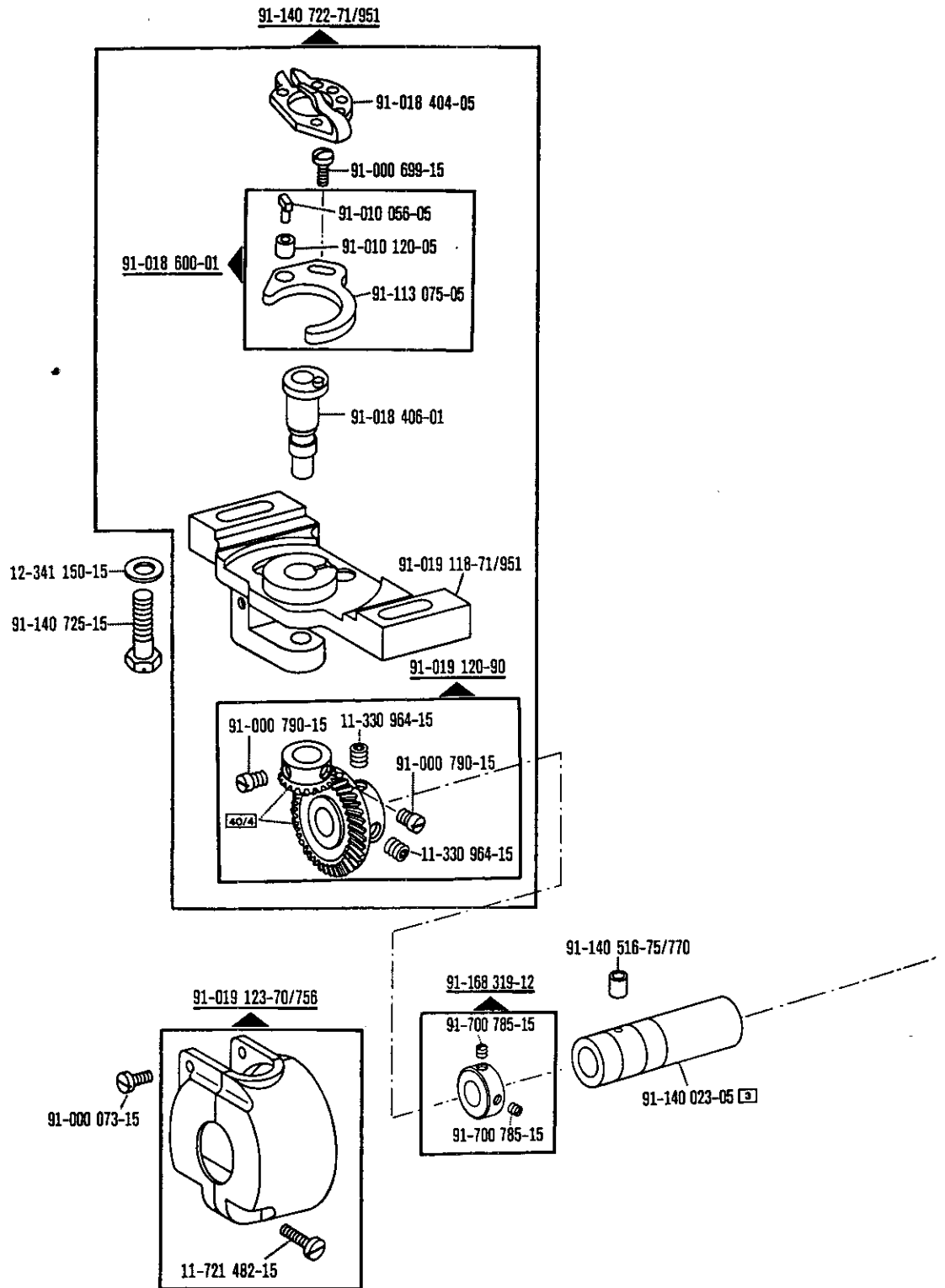

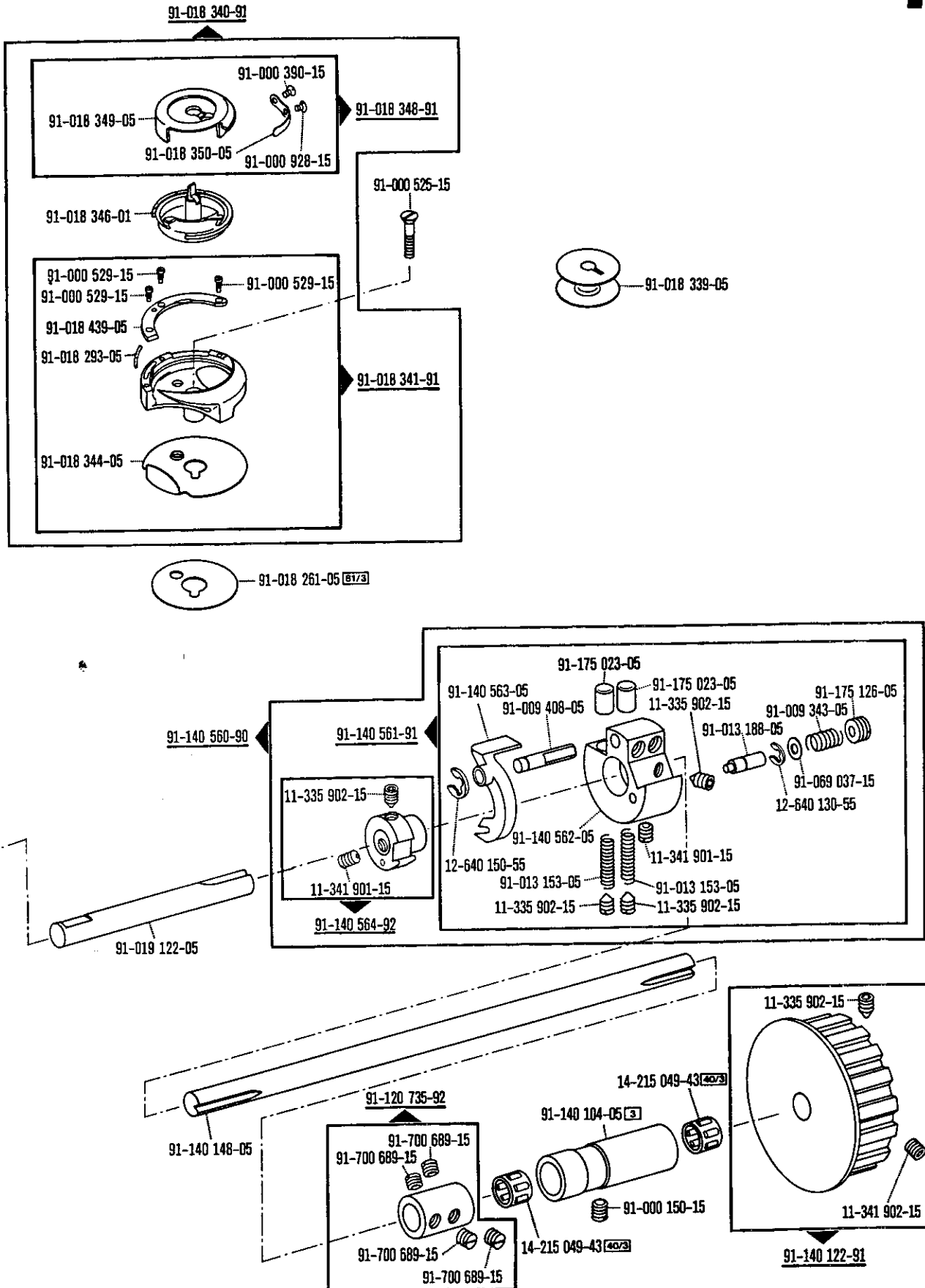

7

Beplatte parts
Pièces du plateau fondamental
Piezas de la placa-base

PFAFF 1245-706/47 CN

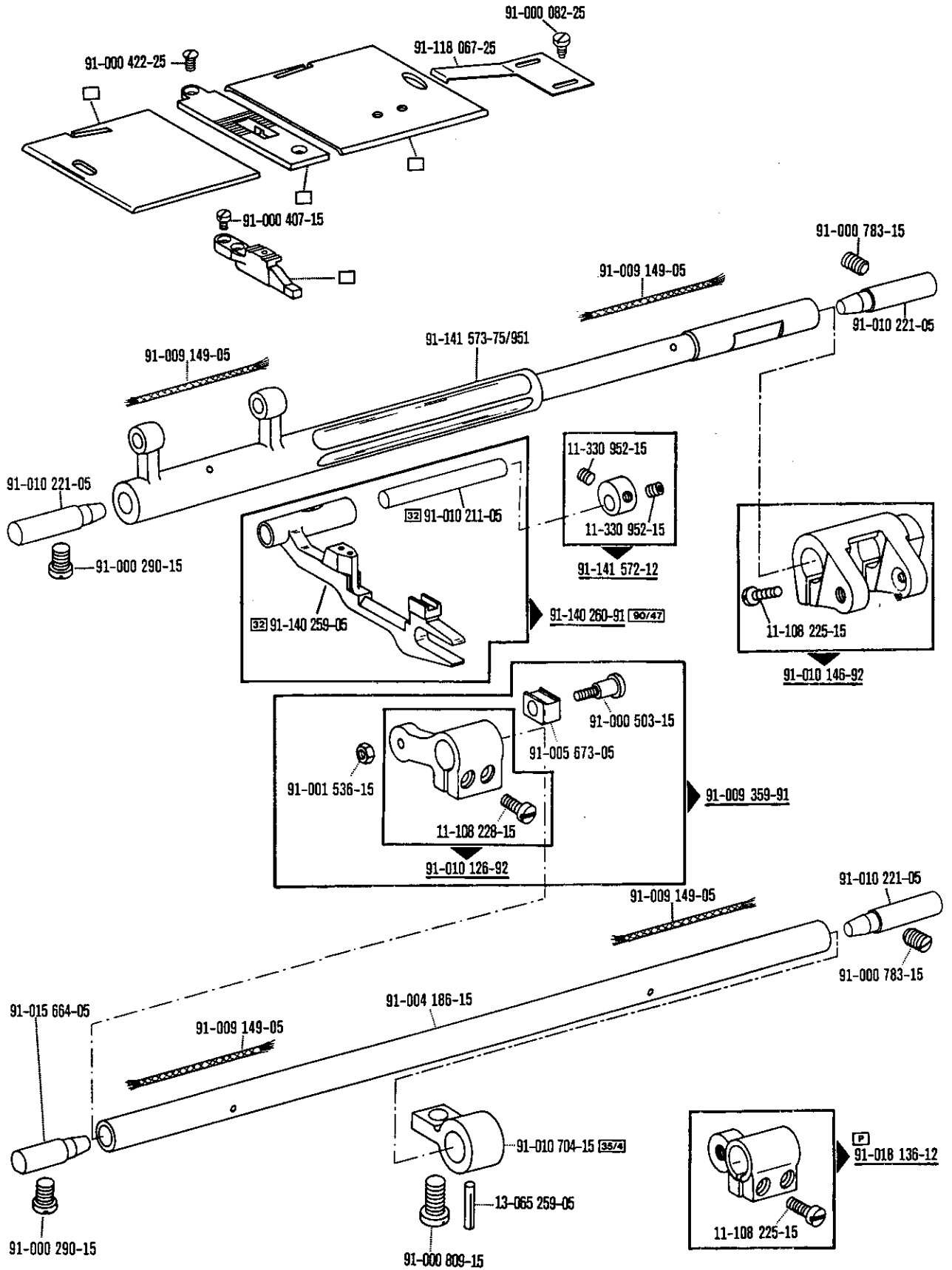

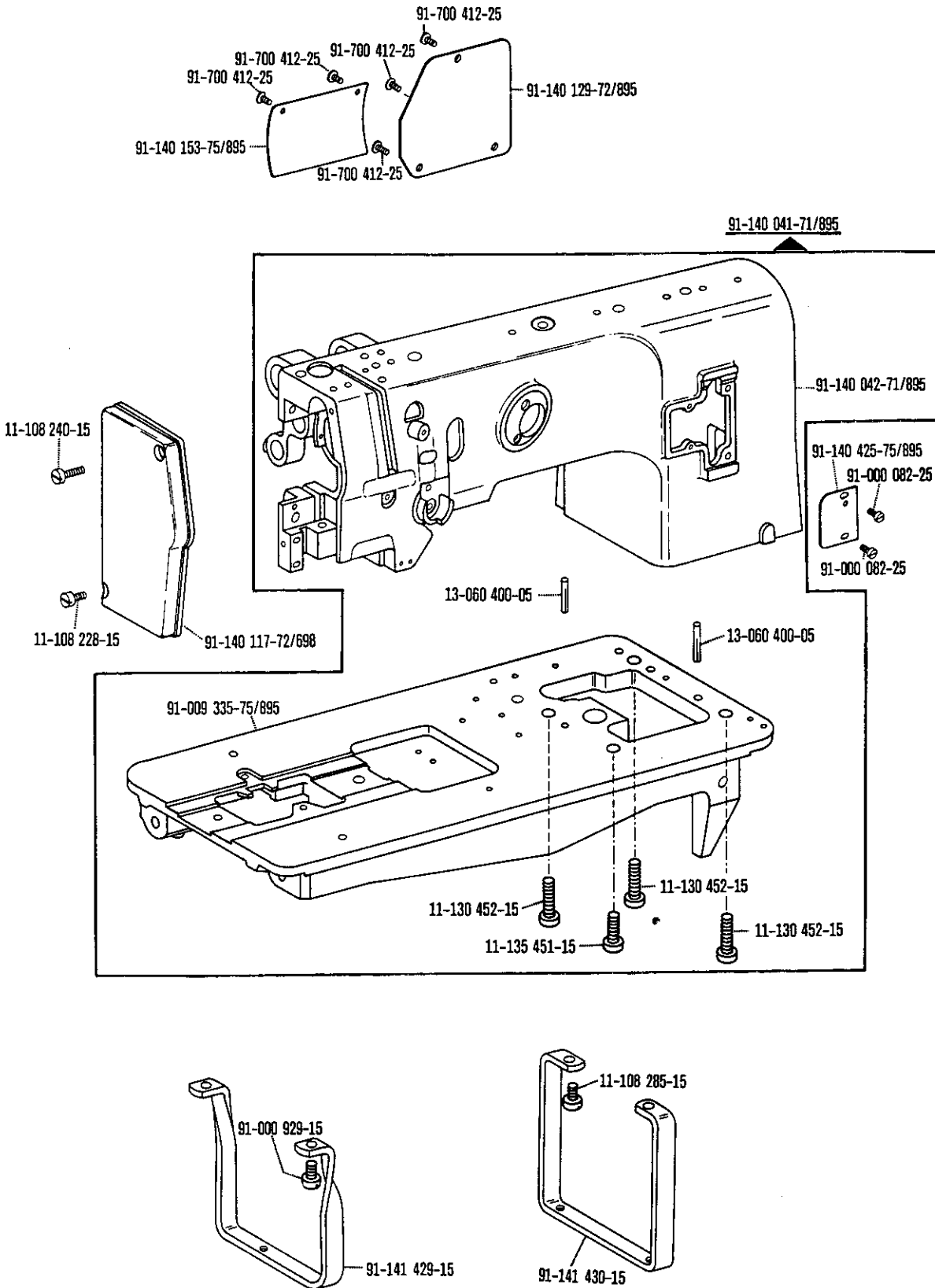

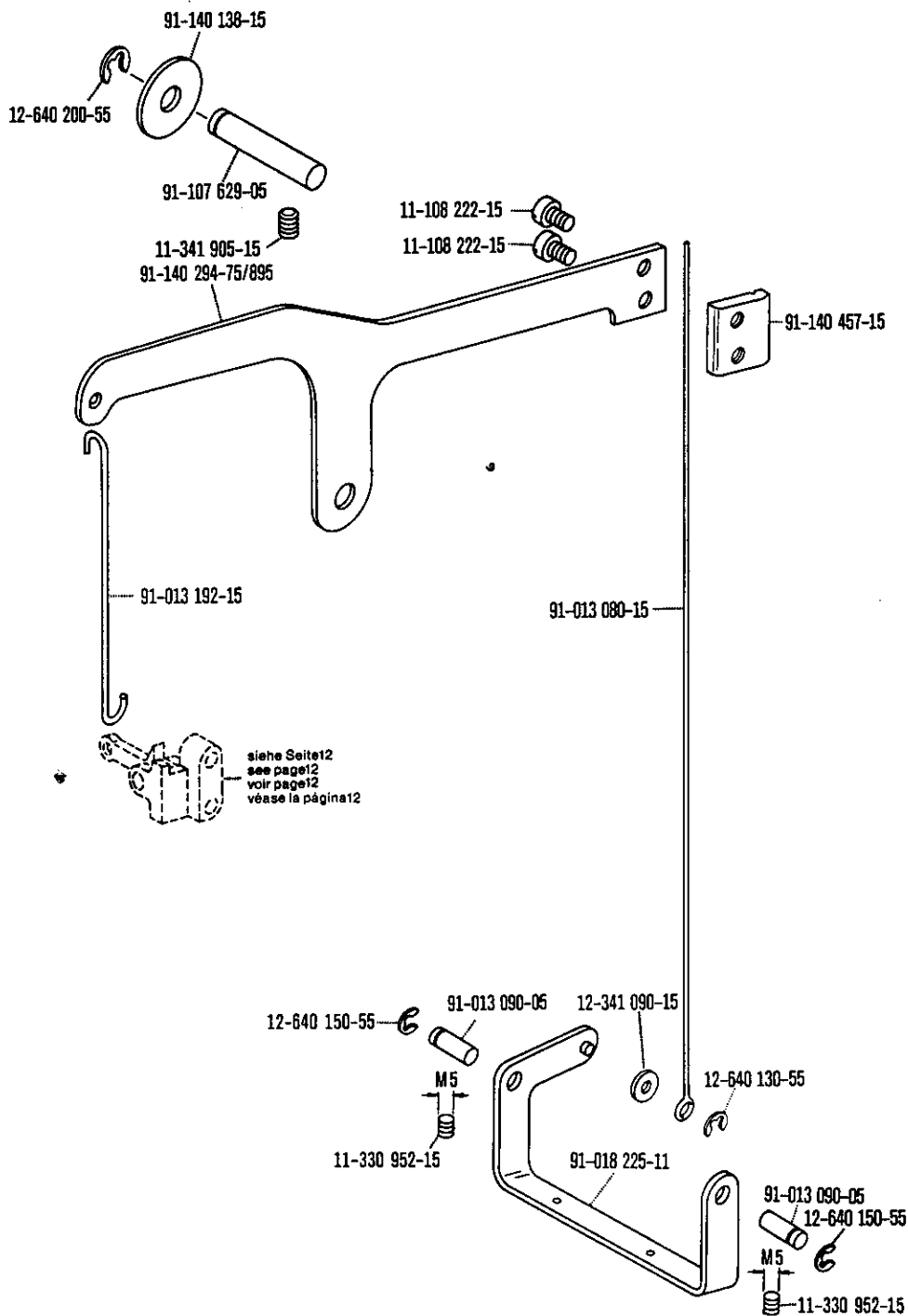

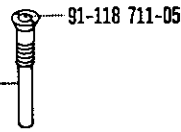
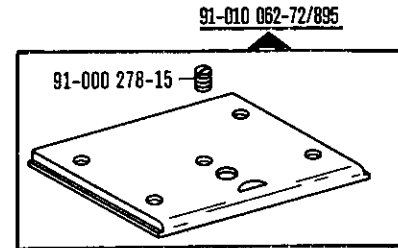
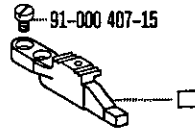
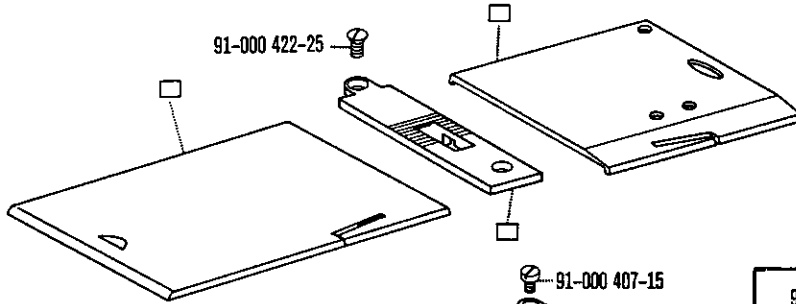
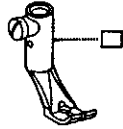

91-140 199-02

91-140 451-91

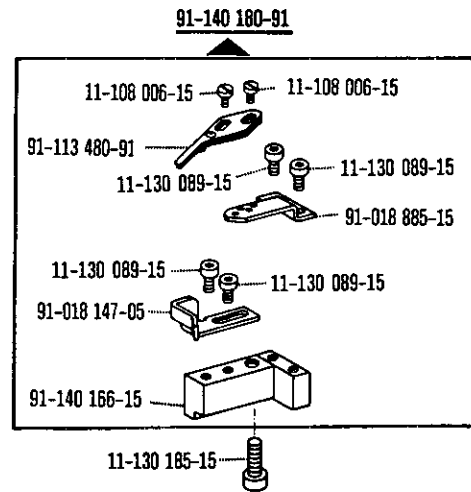
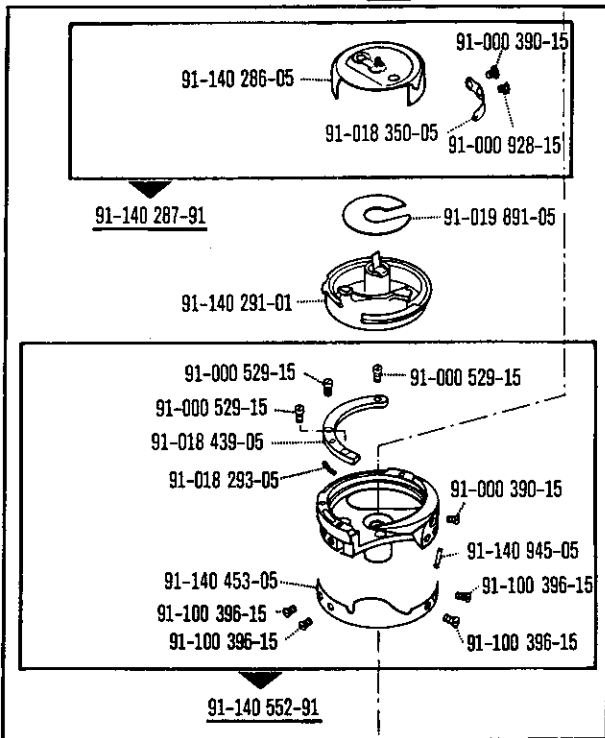

- 91-140 413-05 (0,6) **2772**
- 91-140 256-05 (0,8) **2772**
- 91-140 257-05 (1,0) **2772**
- 91-140 258-05 (1,2) **2772**
- 91-140 414-05 (1,4) **2772**
- 91-140 415-05 (1,6) **2772**



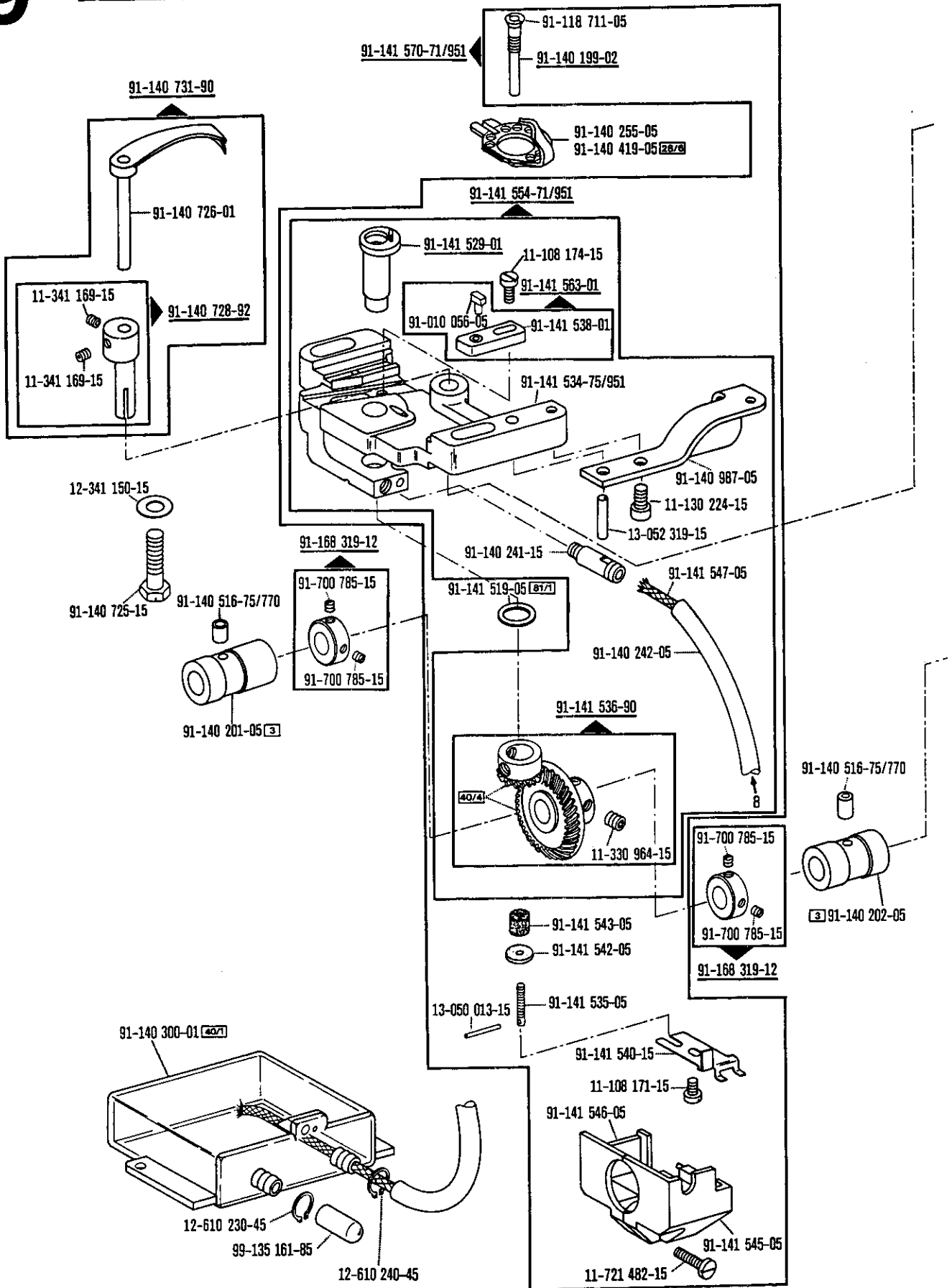

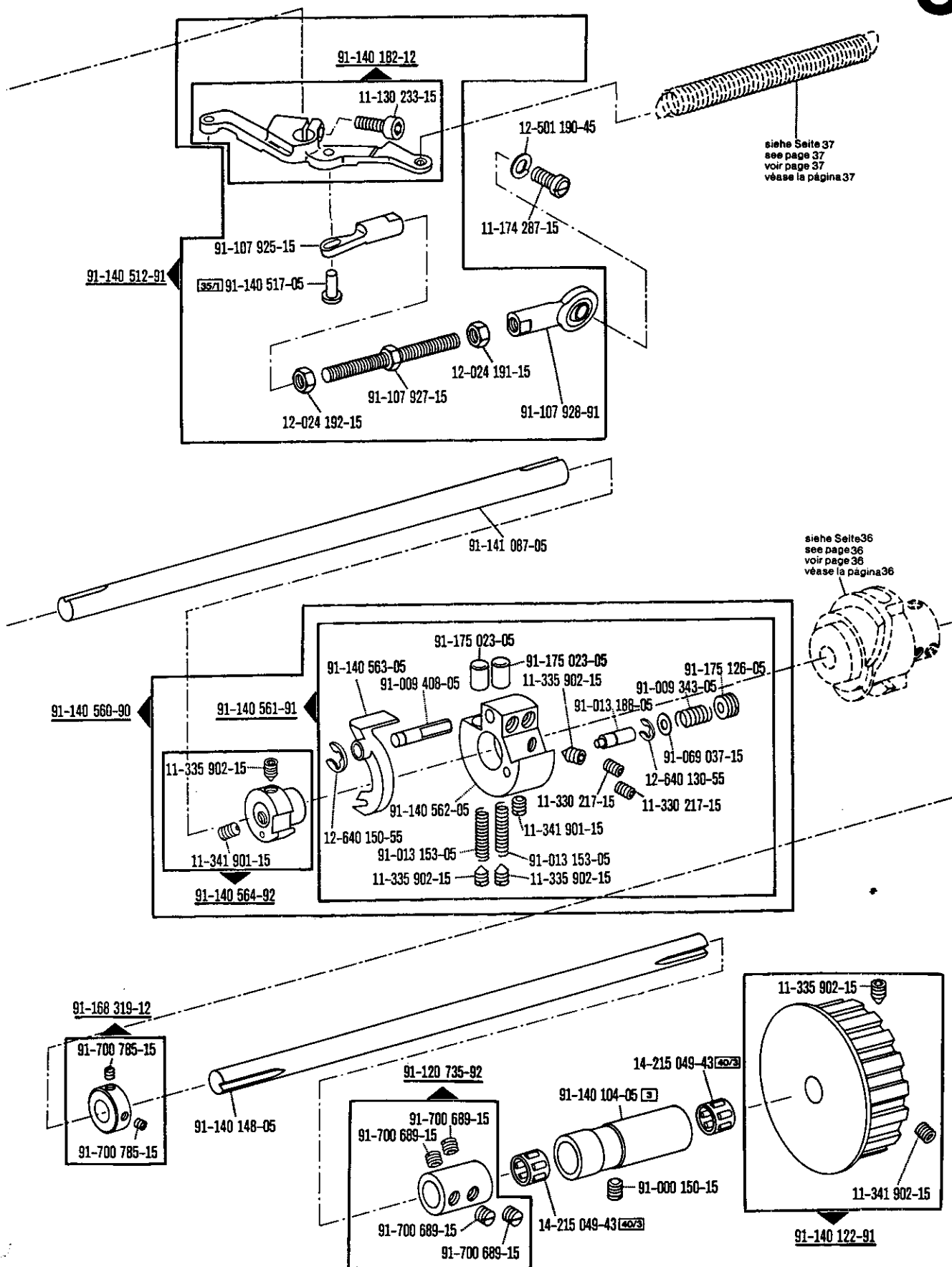

9

**Thread trimmer
Coupe-fil
Cortahillos**

-900/56 zur · pour
for · para PFAFF 1245-706/07 CN; CN 8

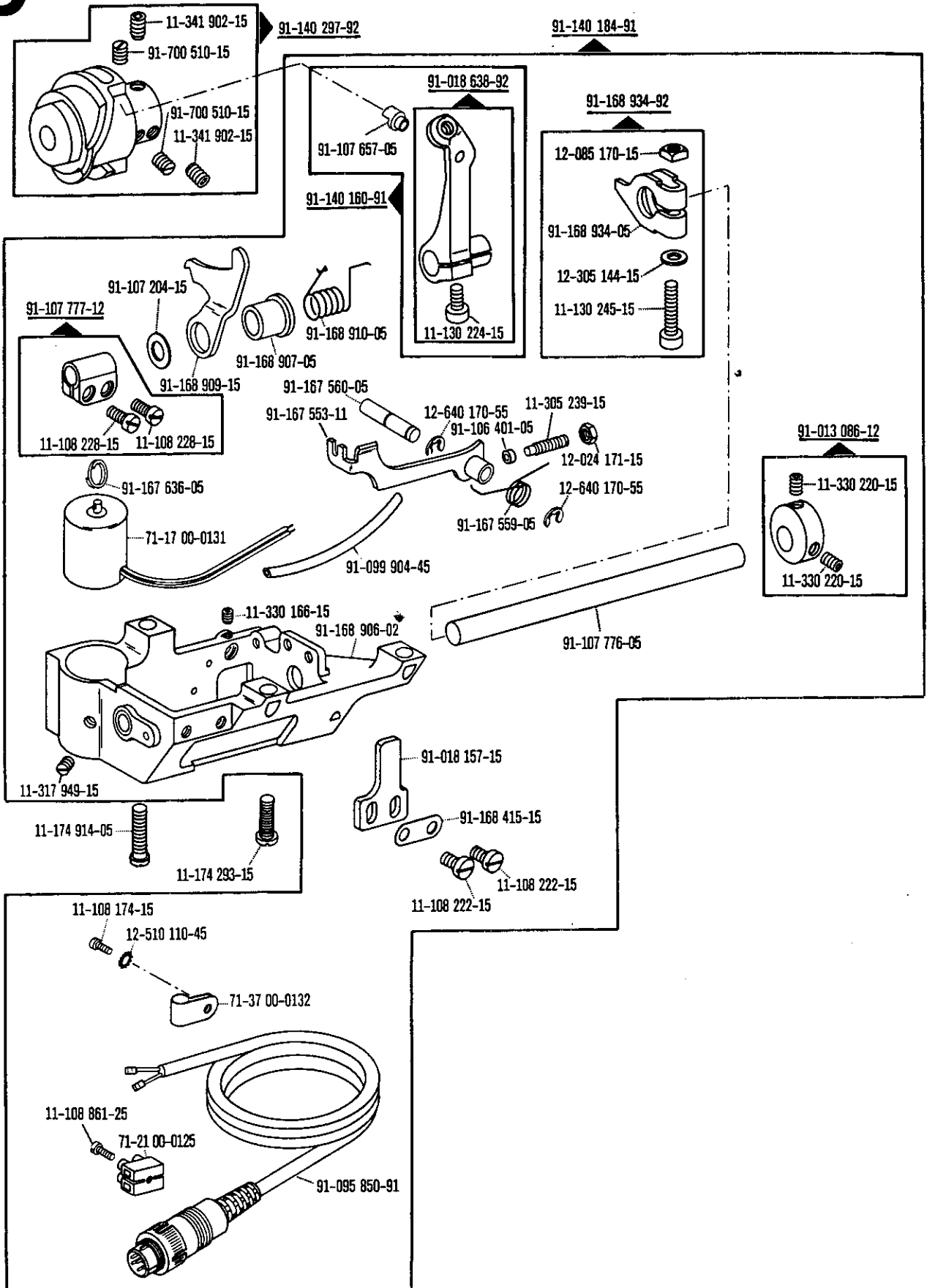

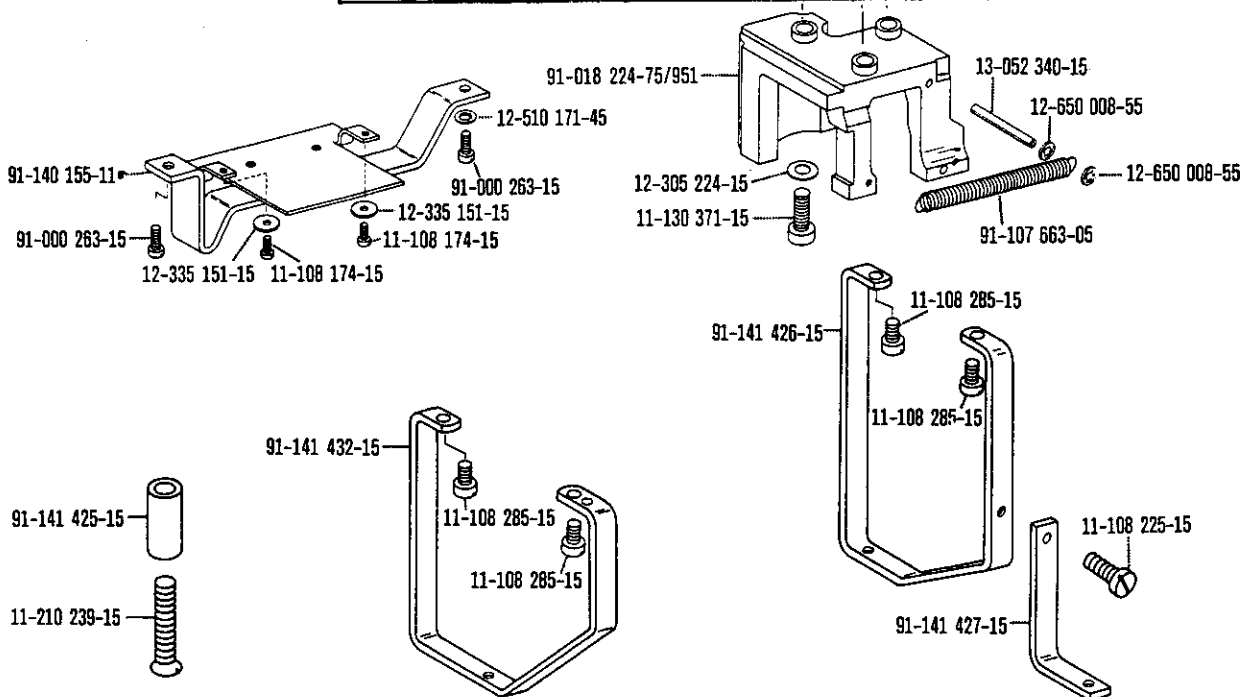
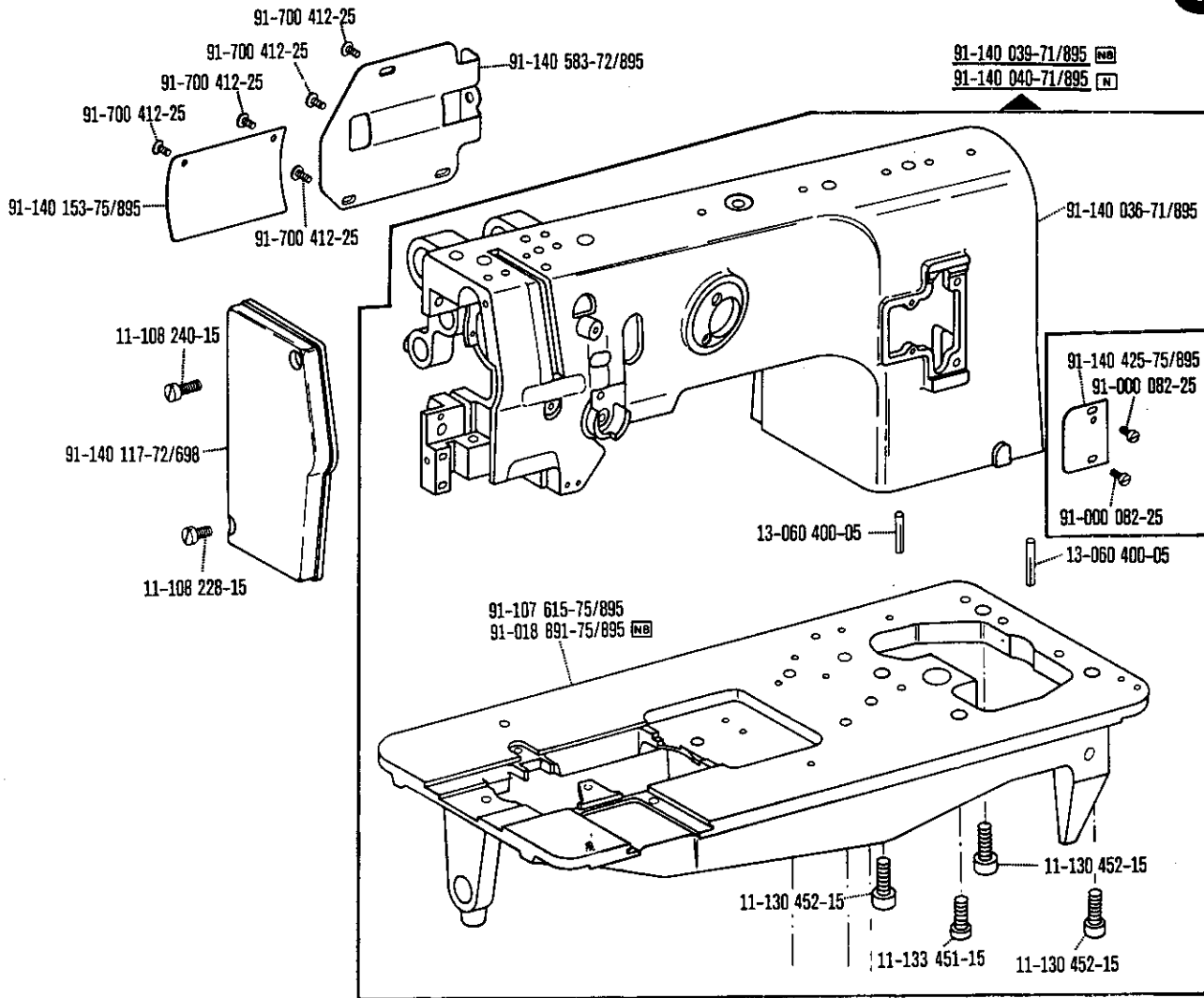

10

Automatic presser foot lifter
Rel-ve-pied automatique
Alzaprensateles

-910/04 zur - pour
 for - para

PFAFF 1245

Conditioning unit -925/02 required
 Conditionneur d'air comprimé -925/02 nécessaire
 Requiere grupo acondicionador del aire comprimido -925/02

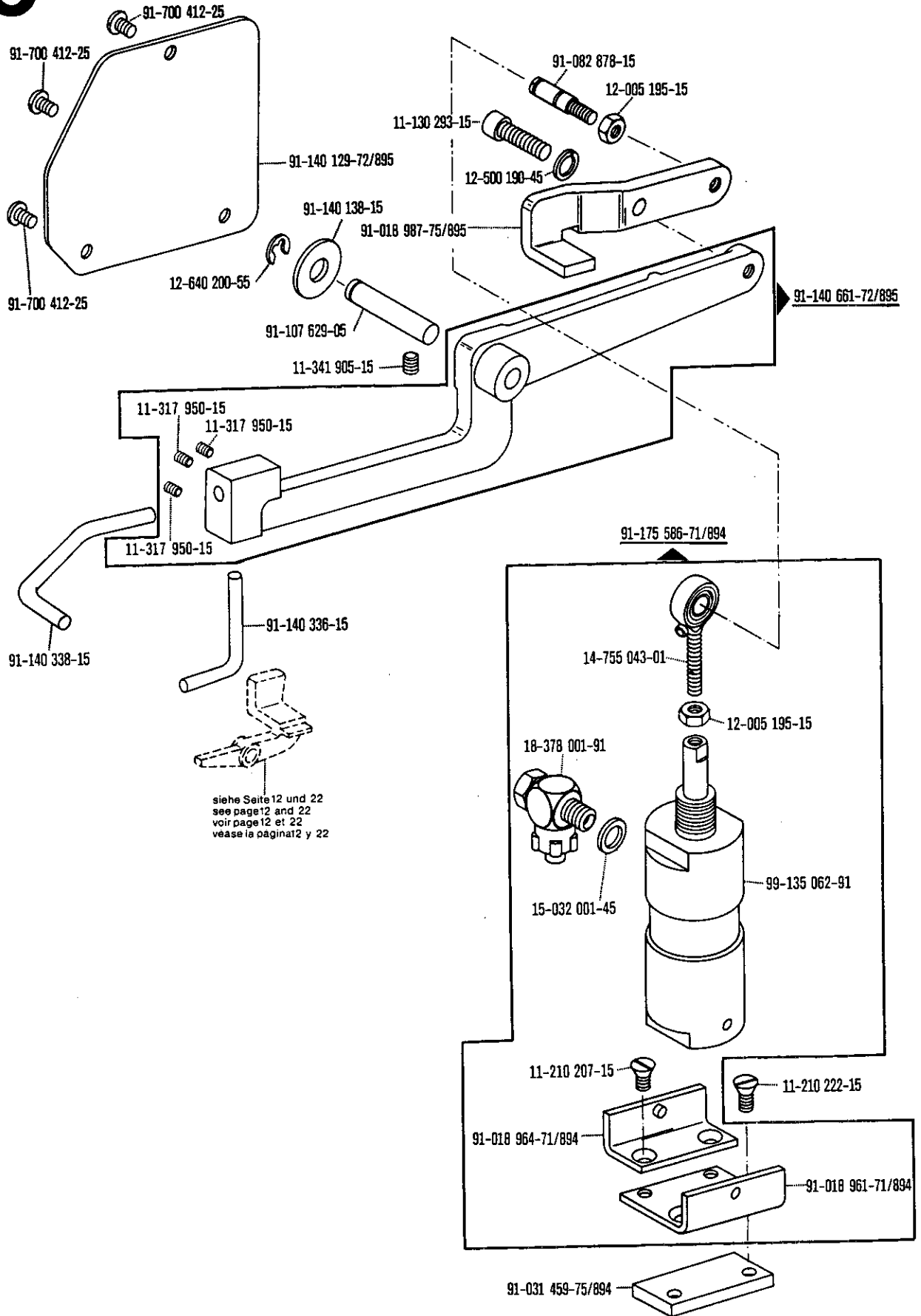

siehe Seite 12 und 22
 see page 12 and 22
 voir page 12 et 22
 véase la paginat 2 y 22

☐ siehe Erläuterungen Register 0
 see explanations in section 0

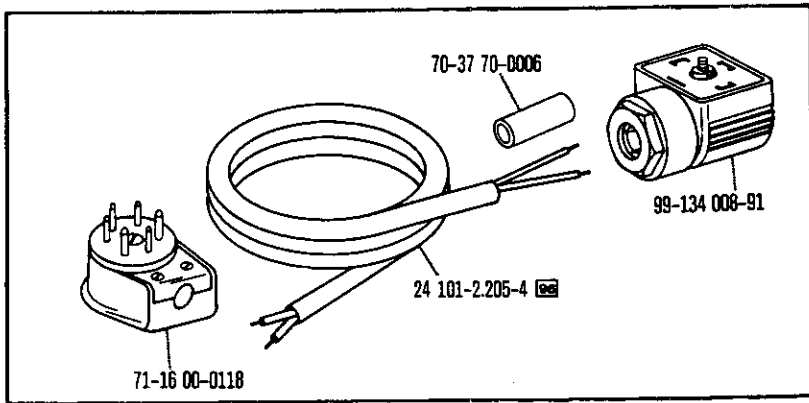
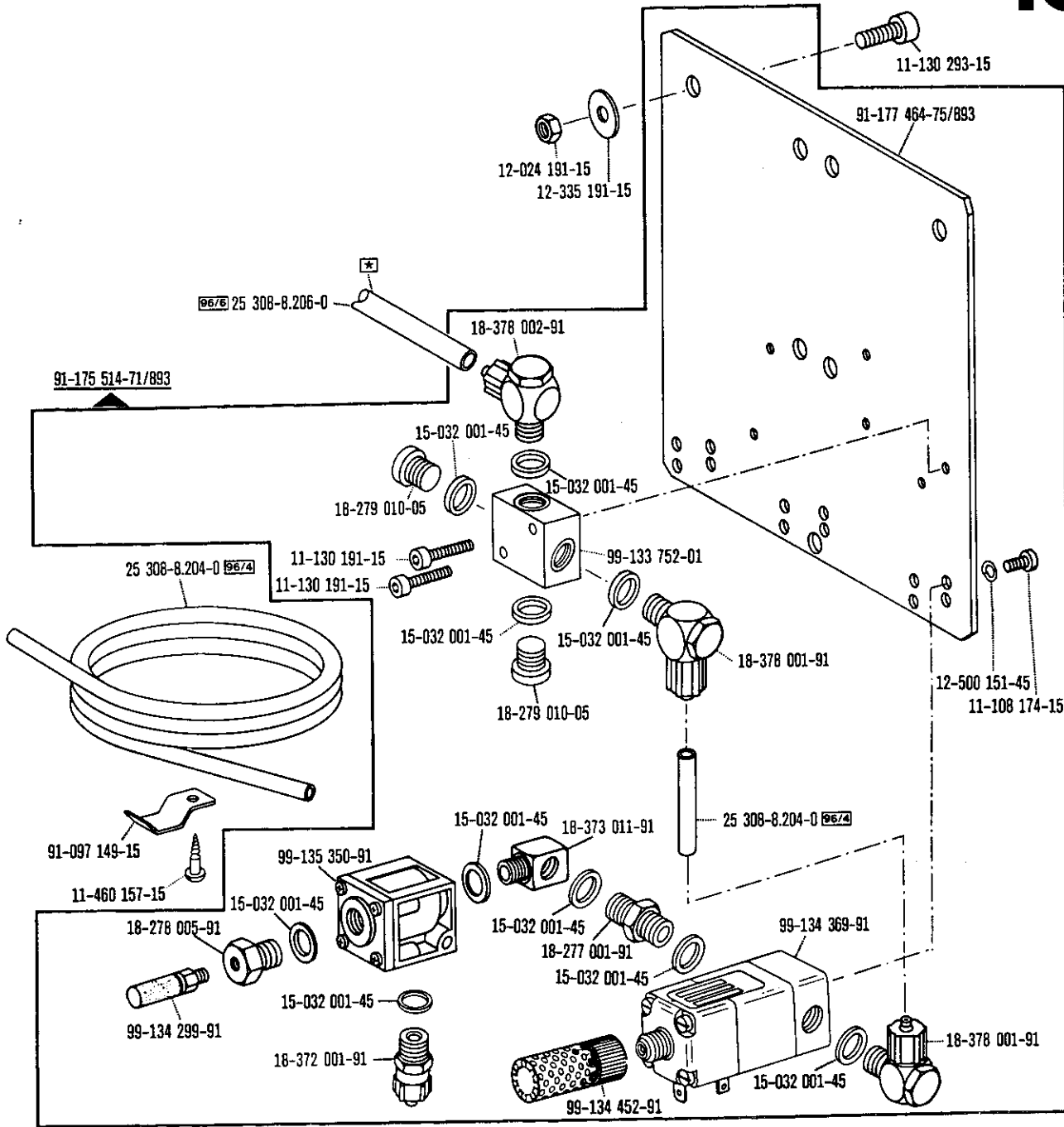

11

Backtacking mechanism Dispositif à points d'arrêt Rematador

Conditioning unit -925/02 required
Conditionneur d'air comprimé -925/02 nécessaire
-911/35*) zur · pour
for · para PFAFF 1245 Requiere grupo acondicionador del aire comprimido -925/02

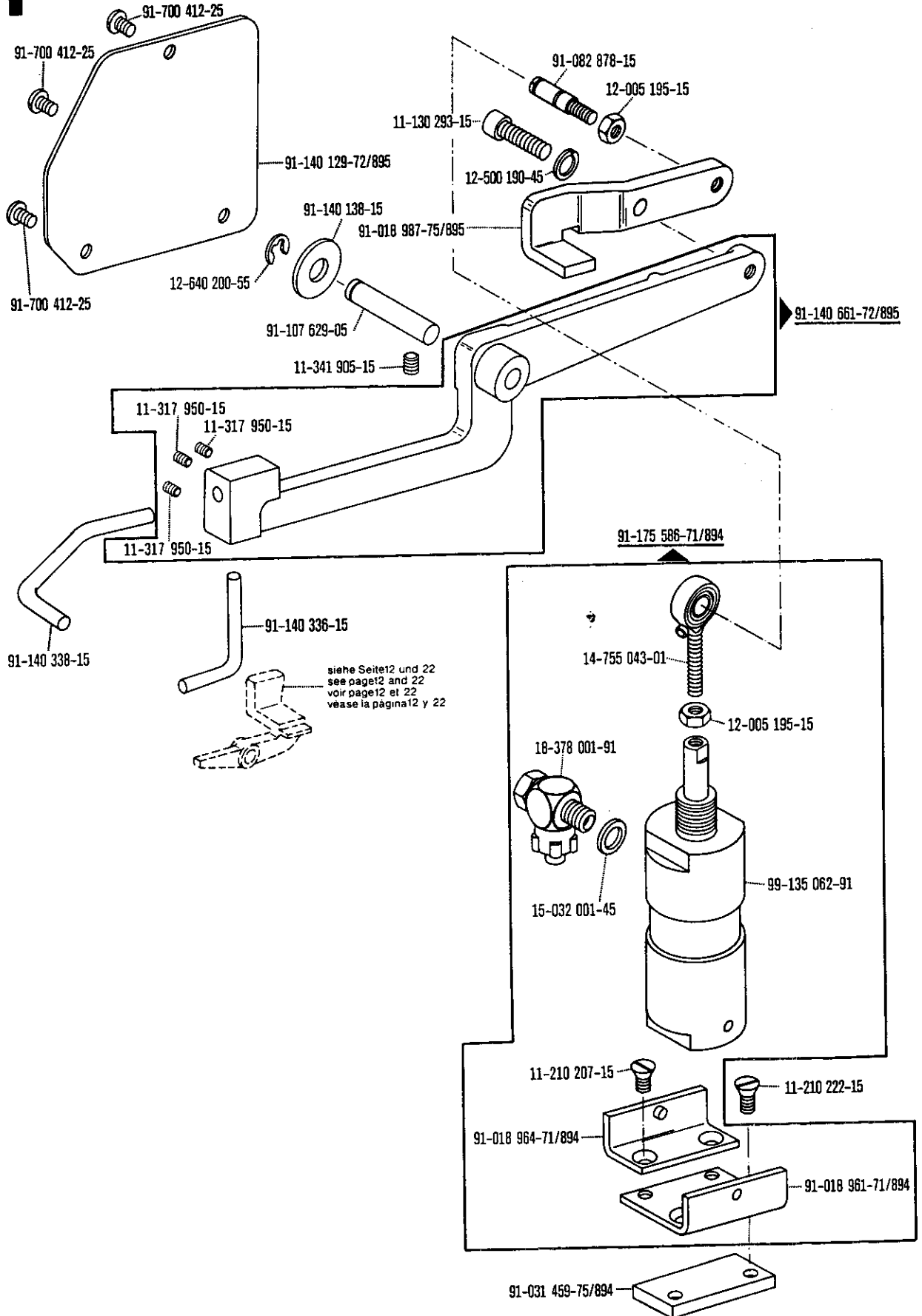

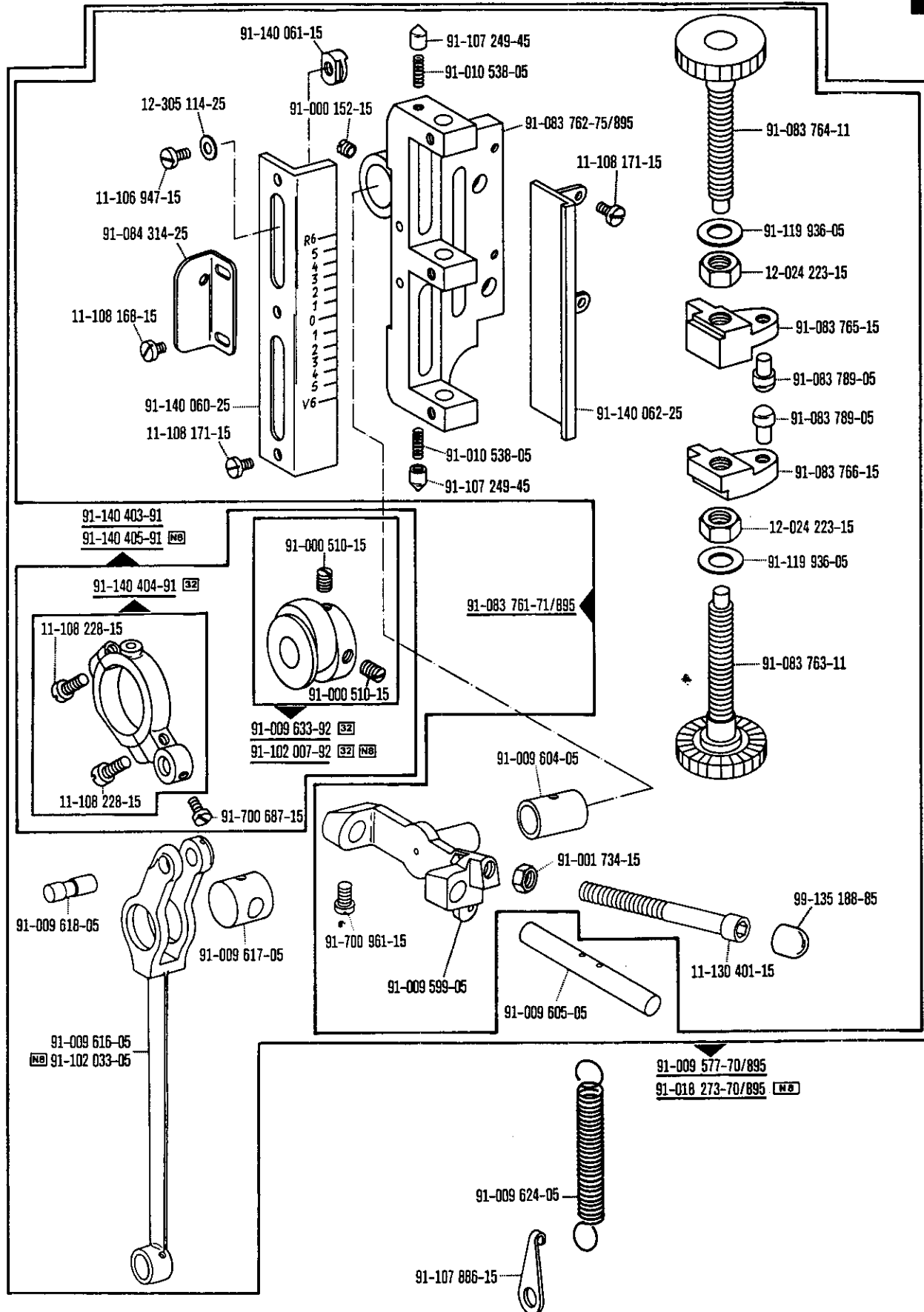

☐ siehe Erläuterungen Register O
see explanations in section O
voir légende registre O

*) Beinhaltet Unterklasse -910/04
Includes subclass -910/04
Comprend la sous-classe -910/04

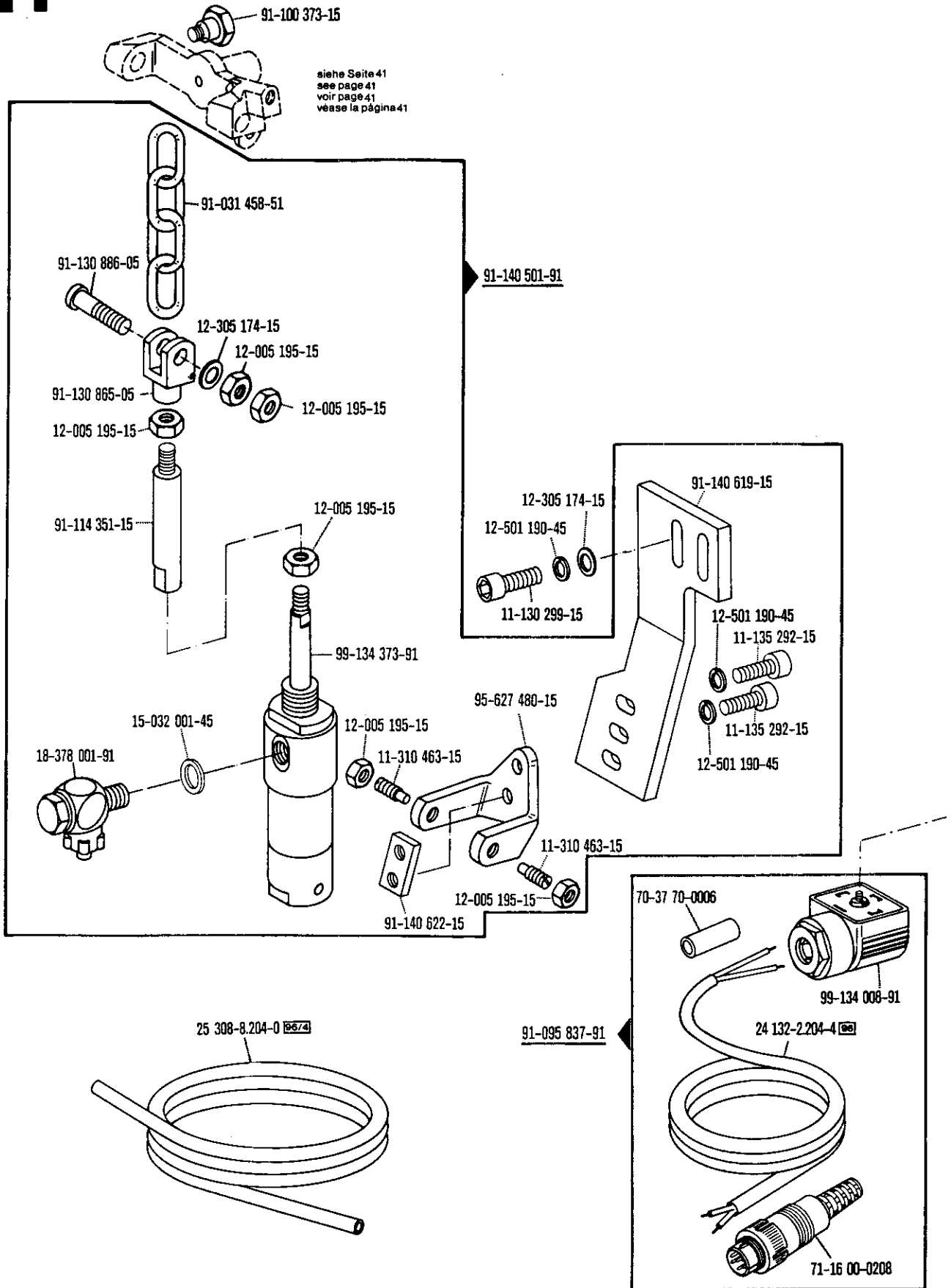

siehe Seite 41
 see page 41
 voir page 41
 vease la página 41

*) Beinhaltet Unterklasse -910/04
 Includes subclass -910/04
 Comprend la sous-classe -910/04

☐ siehe Erläuterungen Register O
 see explanations in section O
 voir l'explication registre O

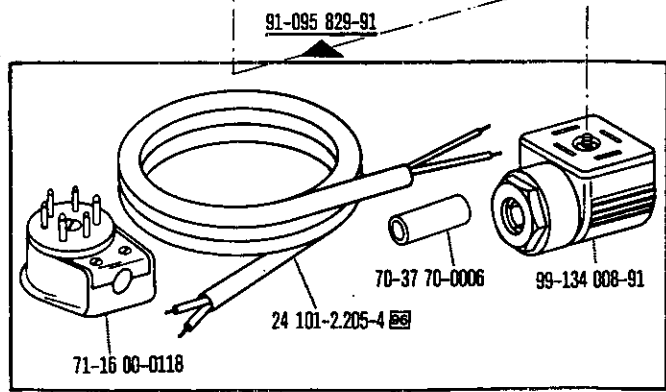
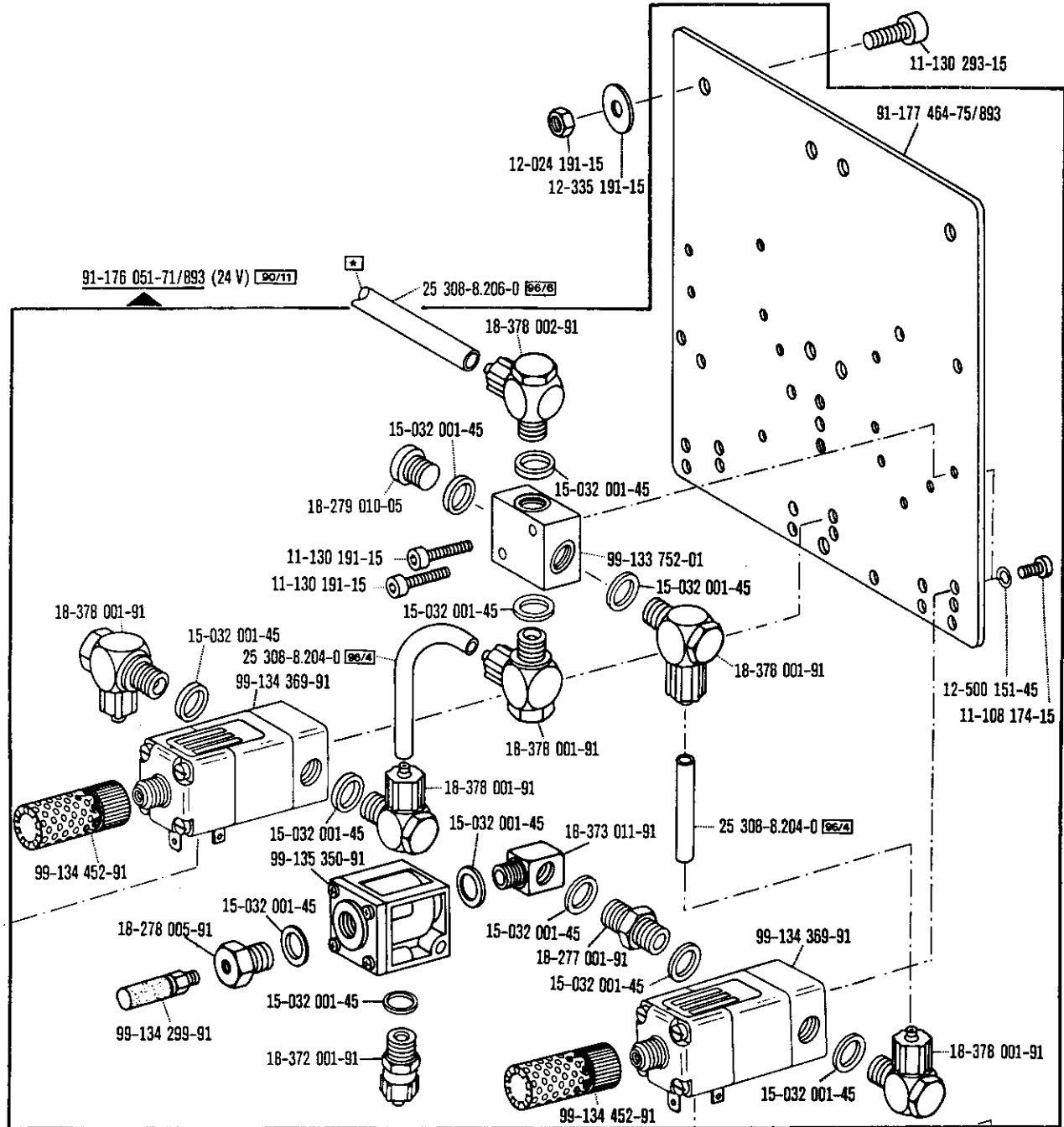

☐ siehe Erläuterungen Register O
 see explanations in section O
 voir légende registre O

*) Beinhaltet Unterklasse -910/04
 Includes subclass -910/04
 Comprend la sous-classe -910/04

☒ Zur Wartungseinheit
 For conditioning unit
 Pour la conditionneur d'air comprimé

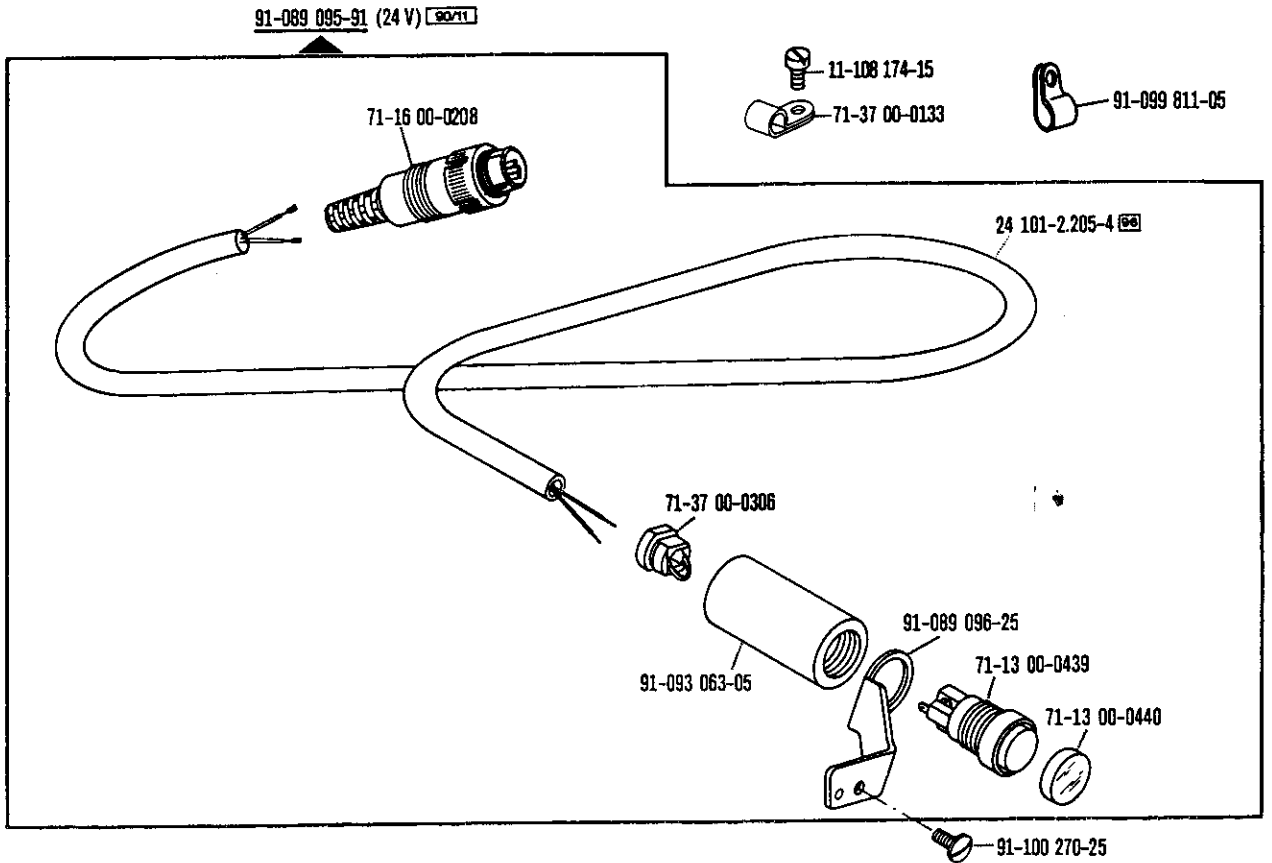

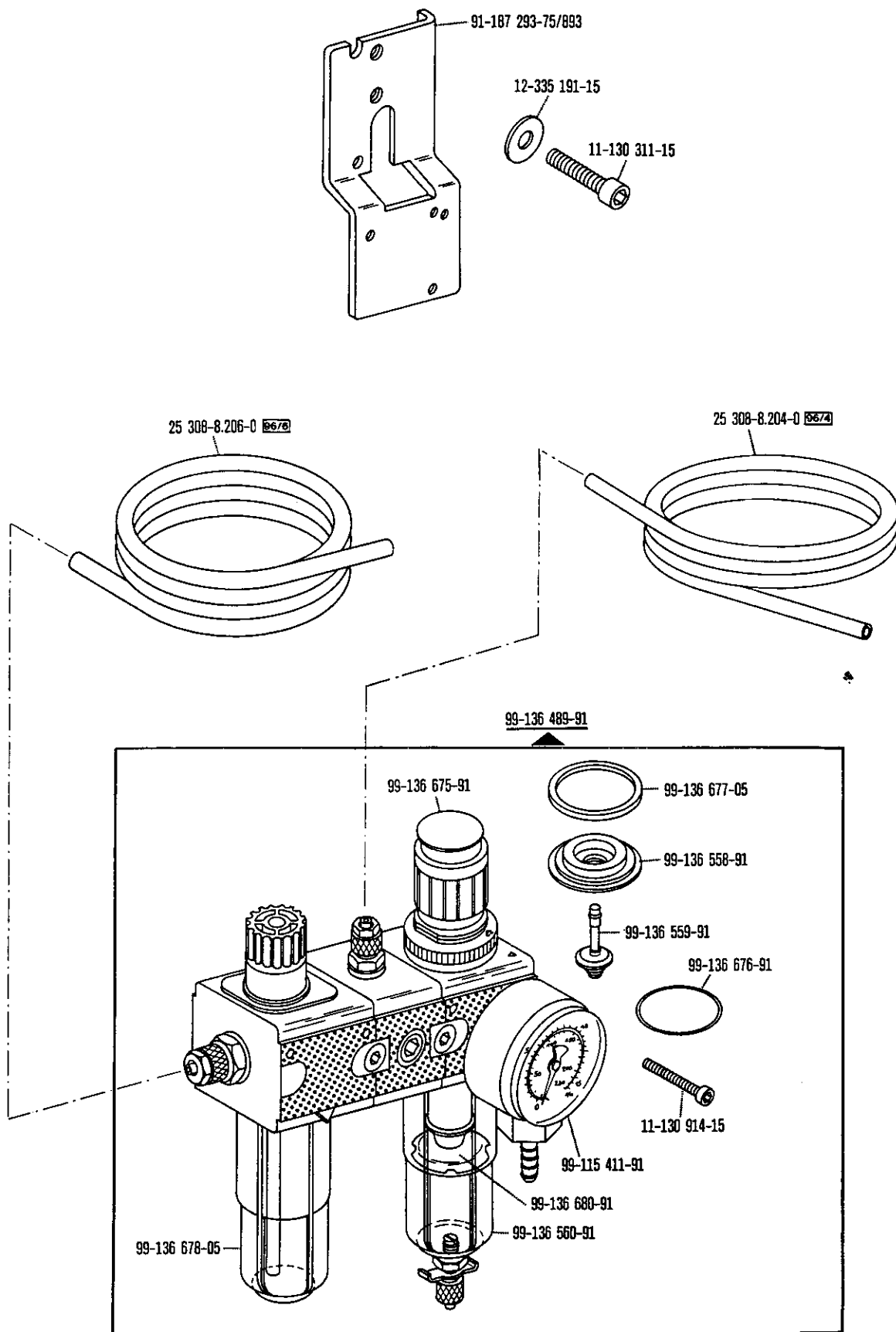

siehe Erläuterungen Register O
 see explanations in section O
 voir légende registre O

13

Accessory parts
Accessoires
Accesorios

zur - pour
for - para PFAFF 1245

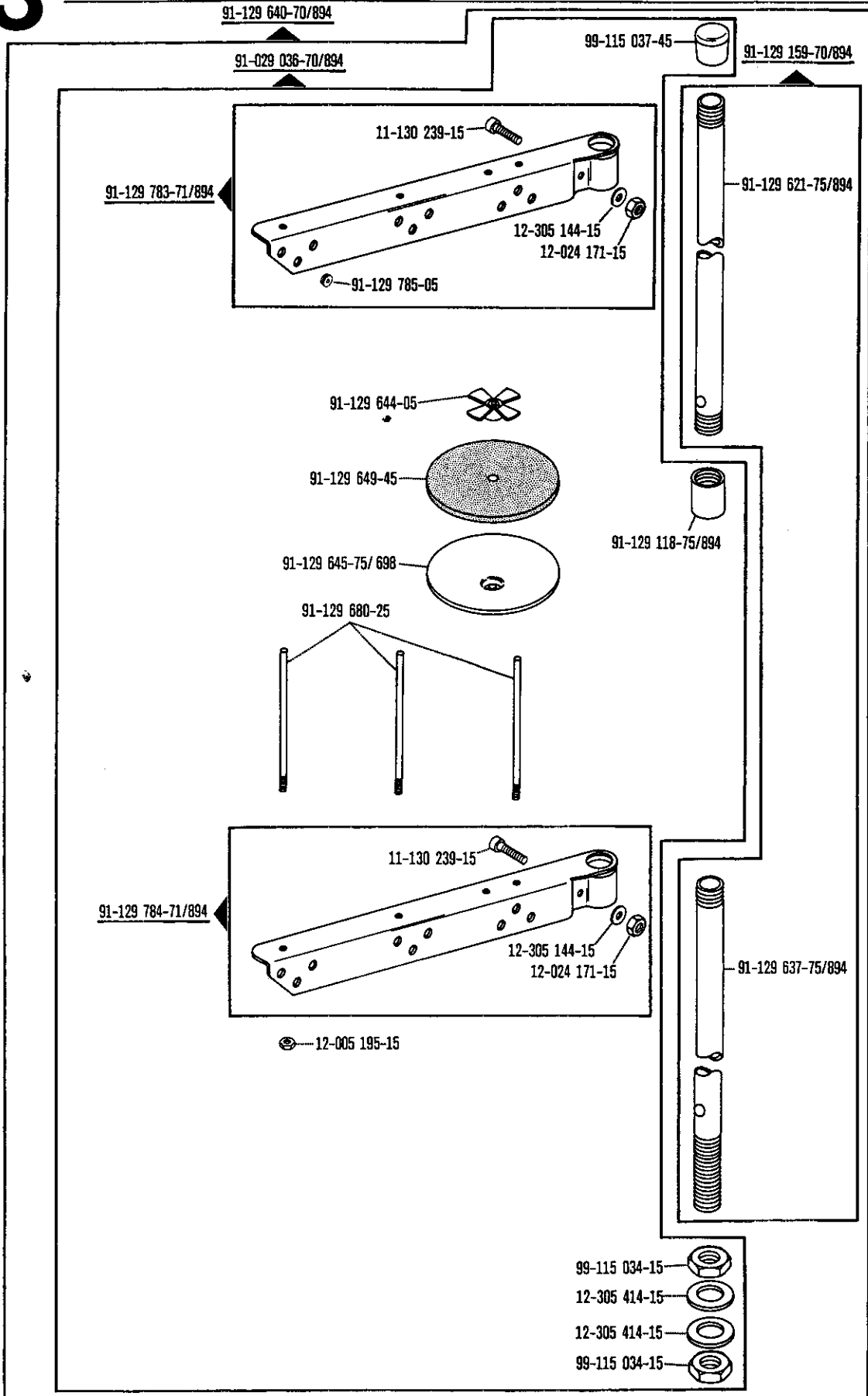

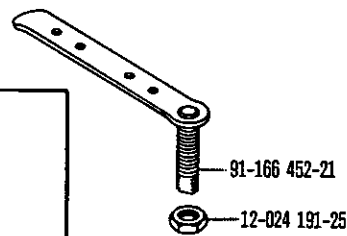
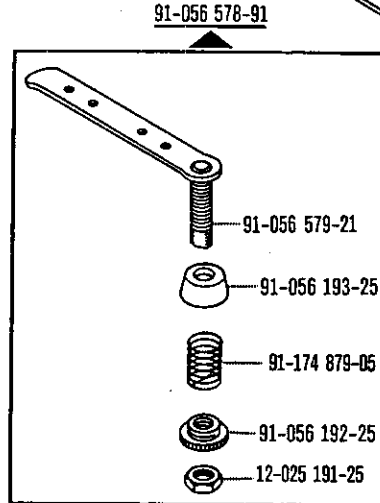
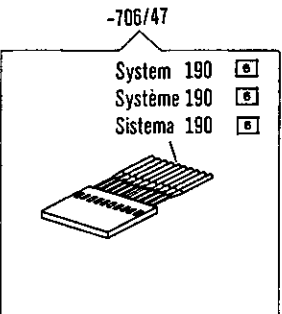
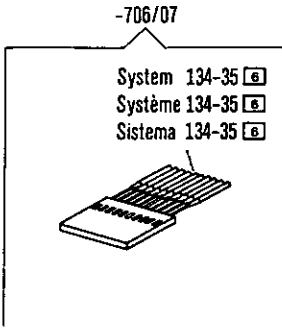

91-029 394-01
 leer
 empty
 vide
 vacía

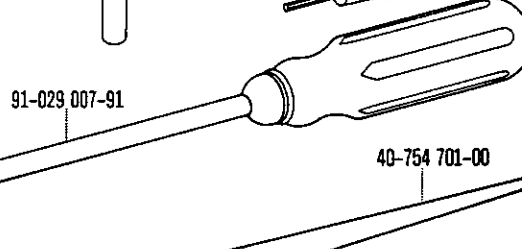
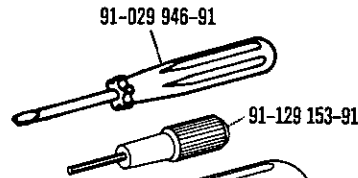
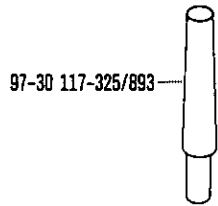
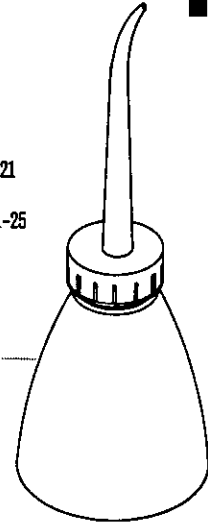

40-754 701-00



40/15 00-136 005-00

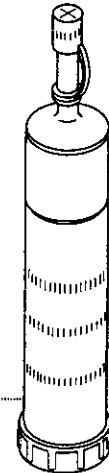

91-018 339-05
 91-018 480-05 (-900/..)

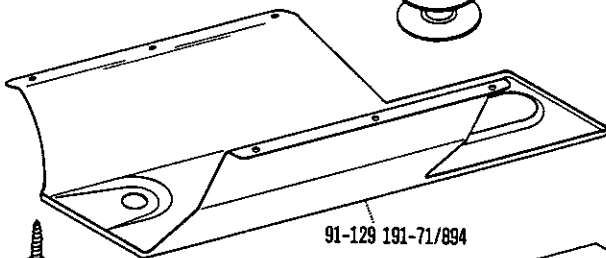
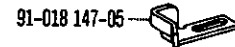
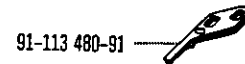

91-129 191-71/894

91-029 033-45

11-460 118-15

91-029 811-05



13

Accessory parts
 Accessoires
 Accesorios

zur - pour
 for - para PFAFF 1245

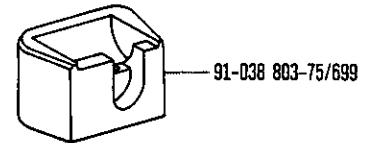
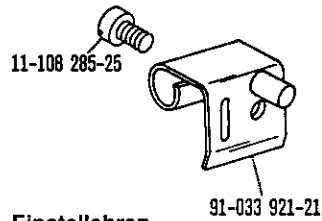
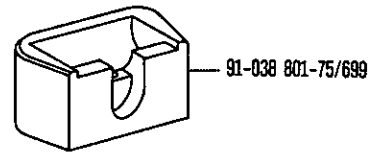
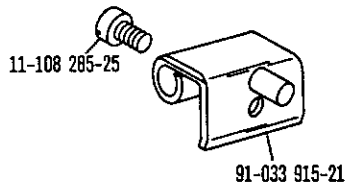
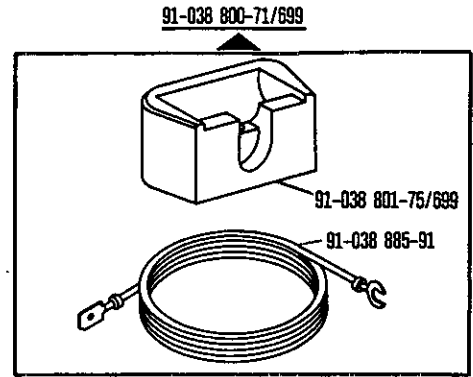
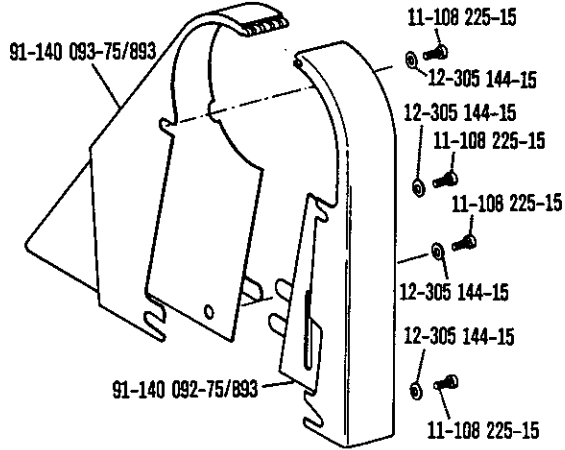

Einstellehren
 Adjustment gauges
 Calibres
 Calibres de ajuste

zur - pour
 for - para PFAFF 1245

14

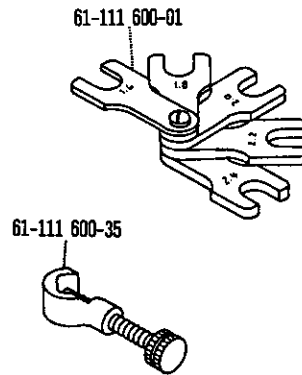

28

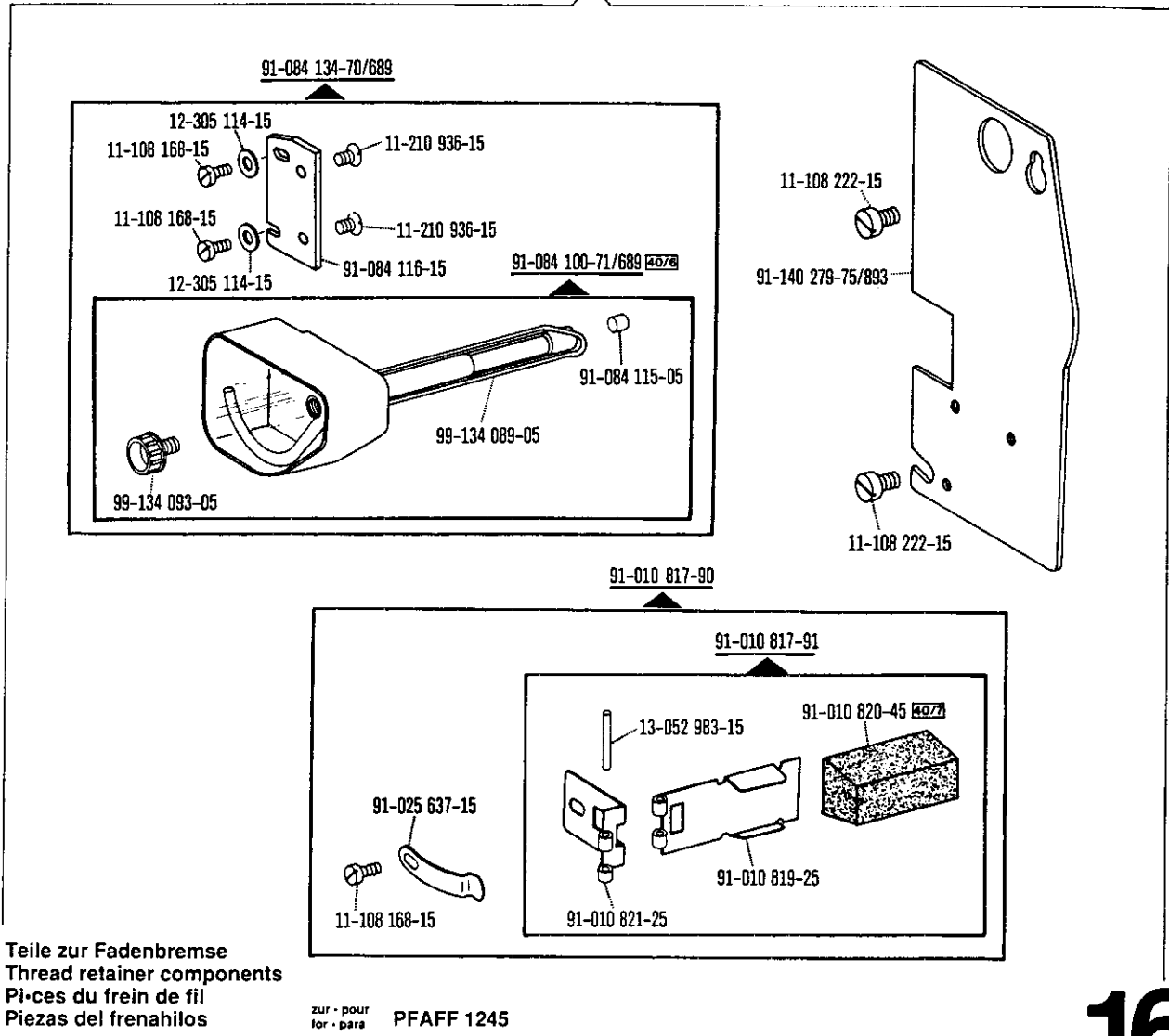

28

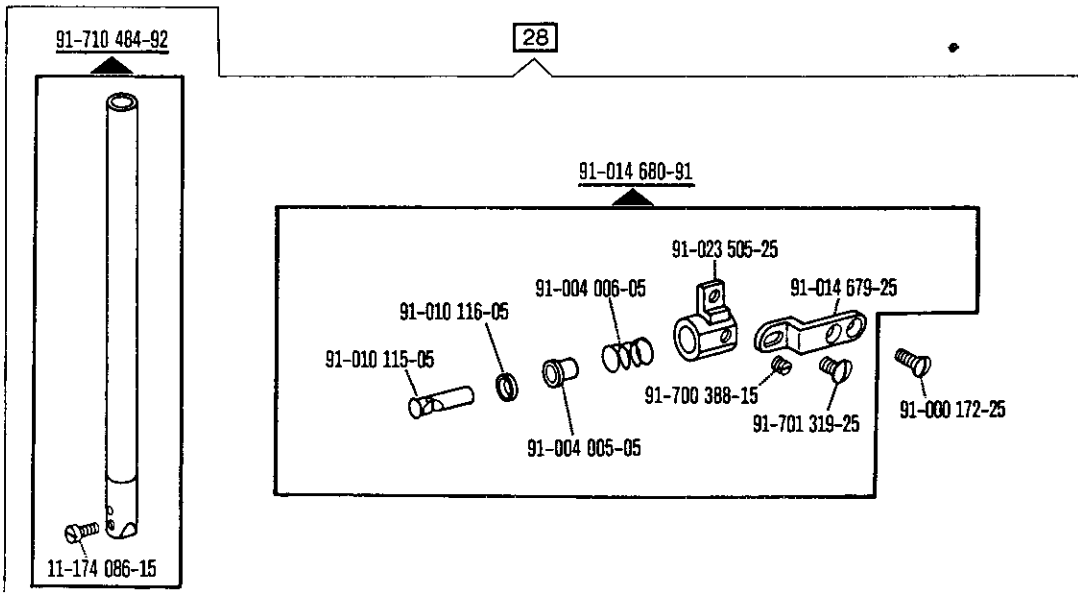

☐ siehe Erläuterungen Register O
 see explanations in section O
 voir légende registre O

17

Knee lifter parts
Pièces du releveur de genouillère
Piezas del alzaprensatelas por rodillera zur · pour
 for · para **PFAFF 1245-706/07**

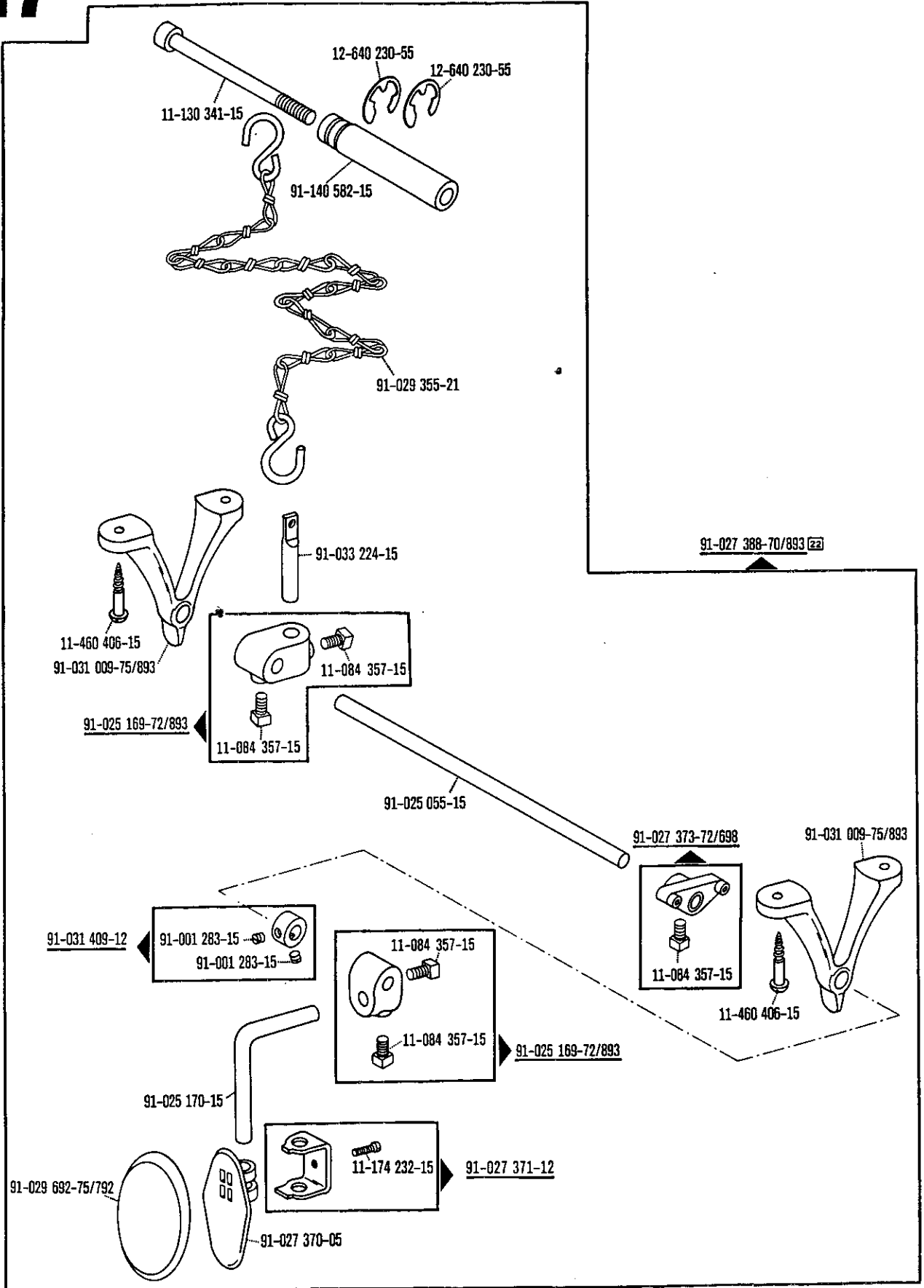

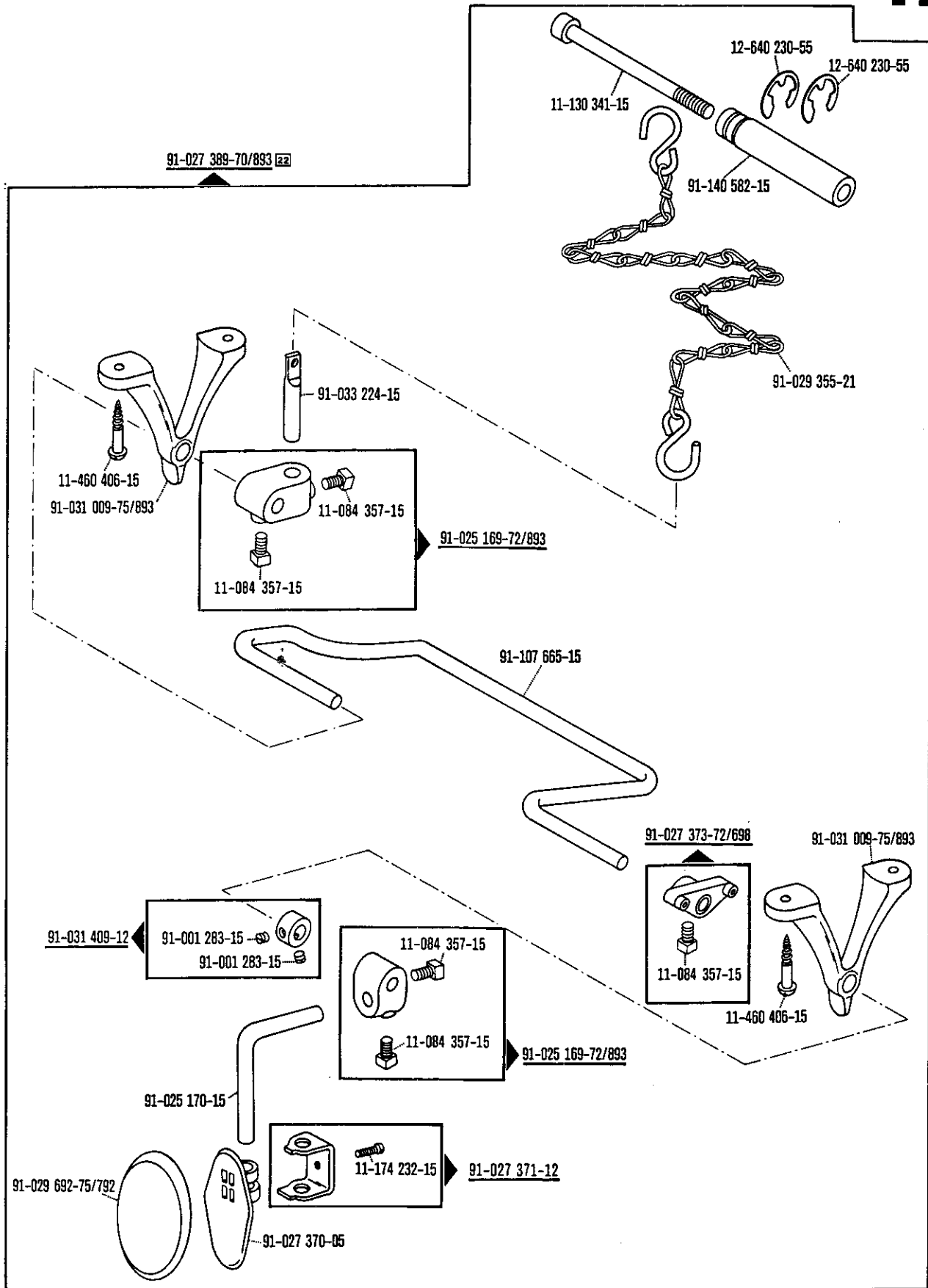

18

Connecting parts for pedal
Raccords de pédale
Piezas de empalme del pedal

zur - pour
for - para PFAFF 1245

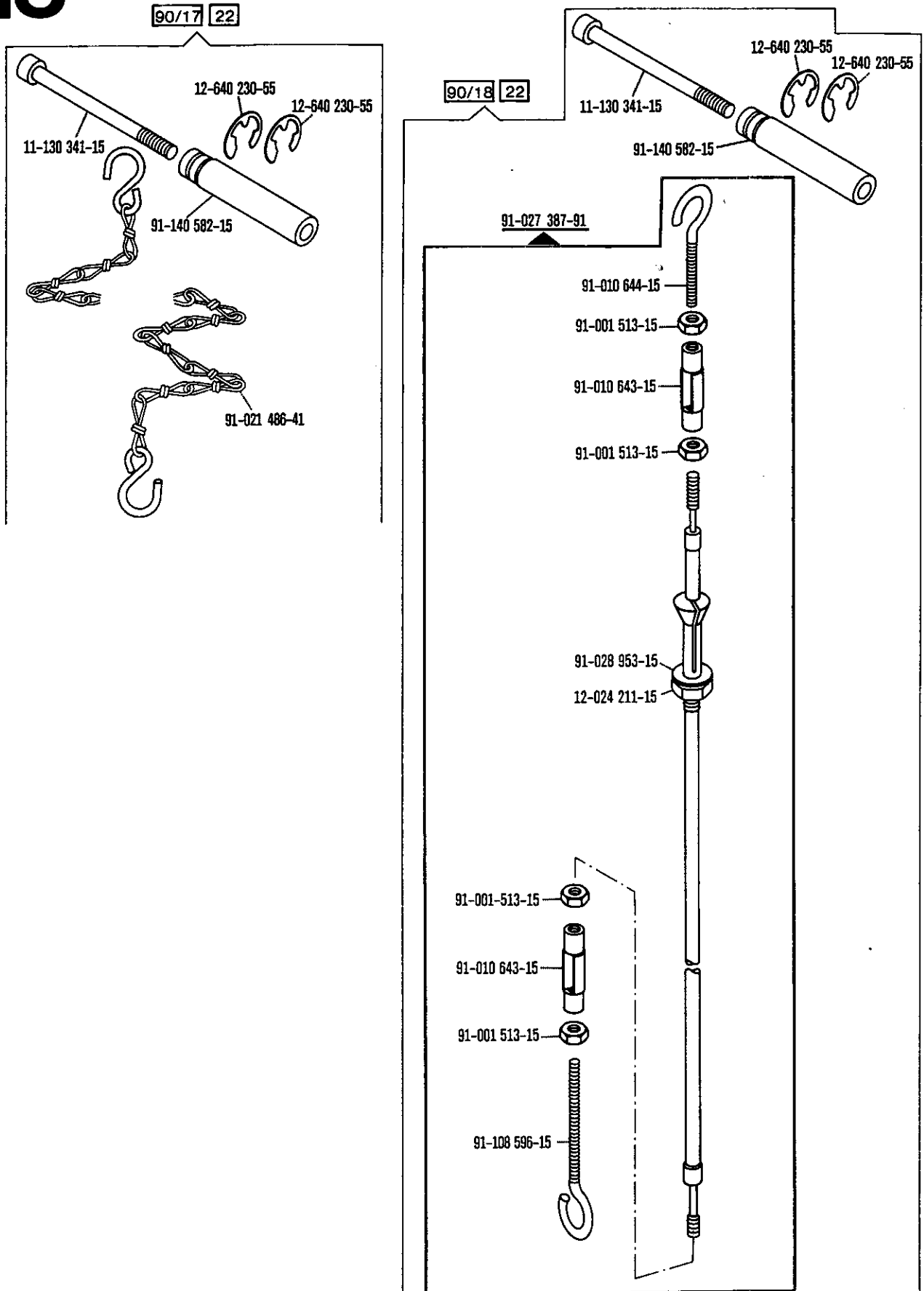

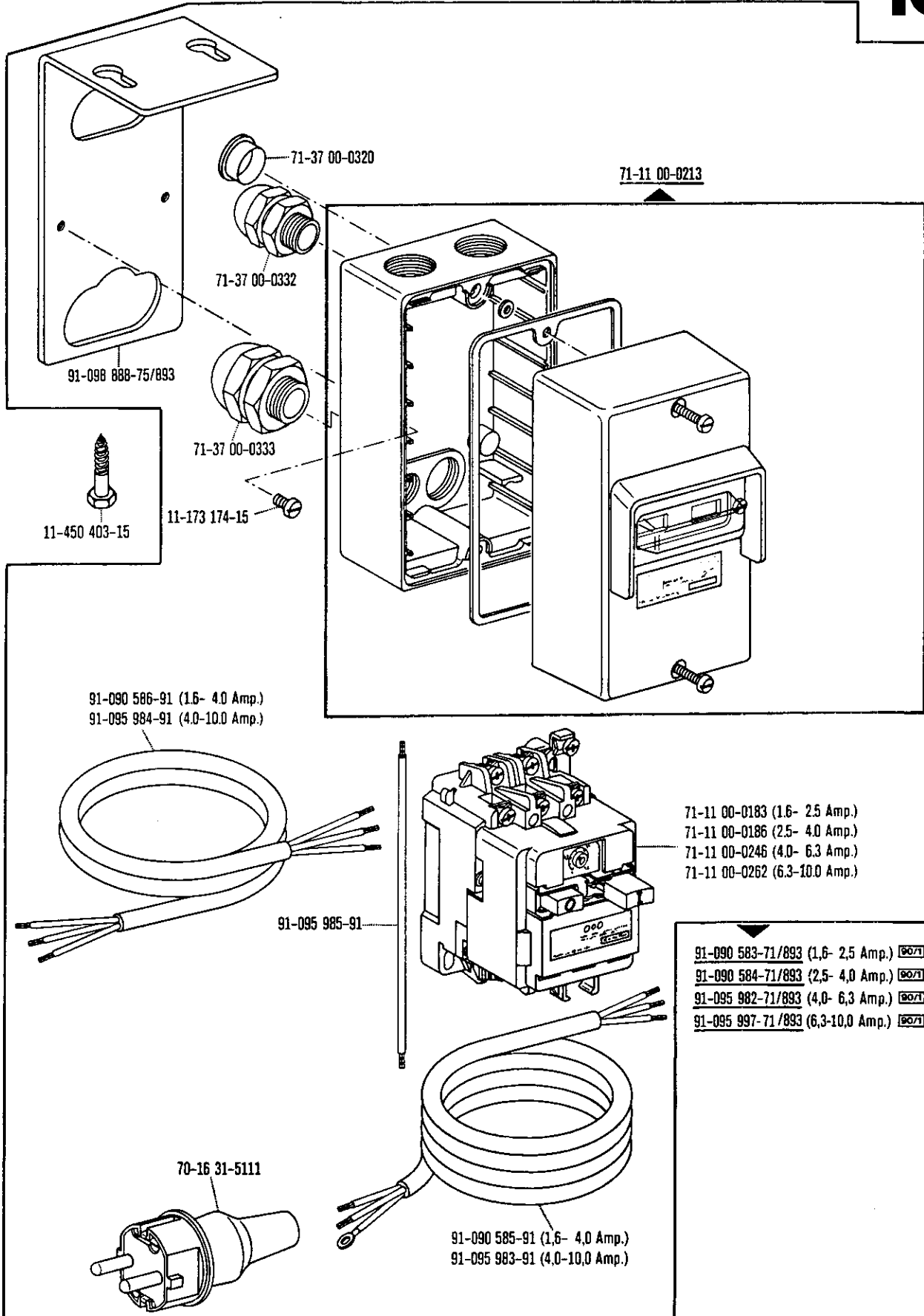

☐ siehe Erläuterungen Register O
 see explanations in section O
 voir légende registre O

19

Jeu de pièces à raccorder le moteur
 Juego de piezas de conexión del motor

(avec contacteur-disjoncteur)
 (con interruptor de seguridad)

Zur - pour
 for - para **PFAFF 1245**

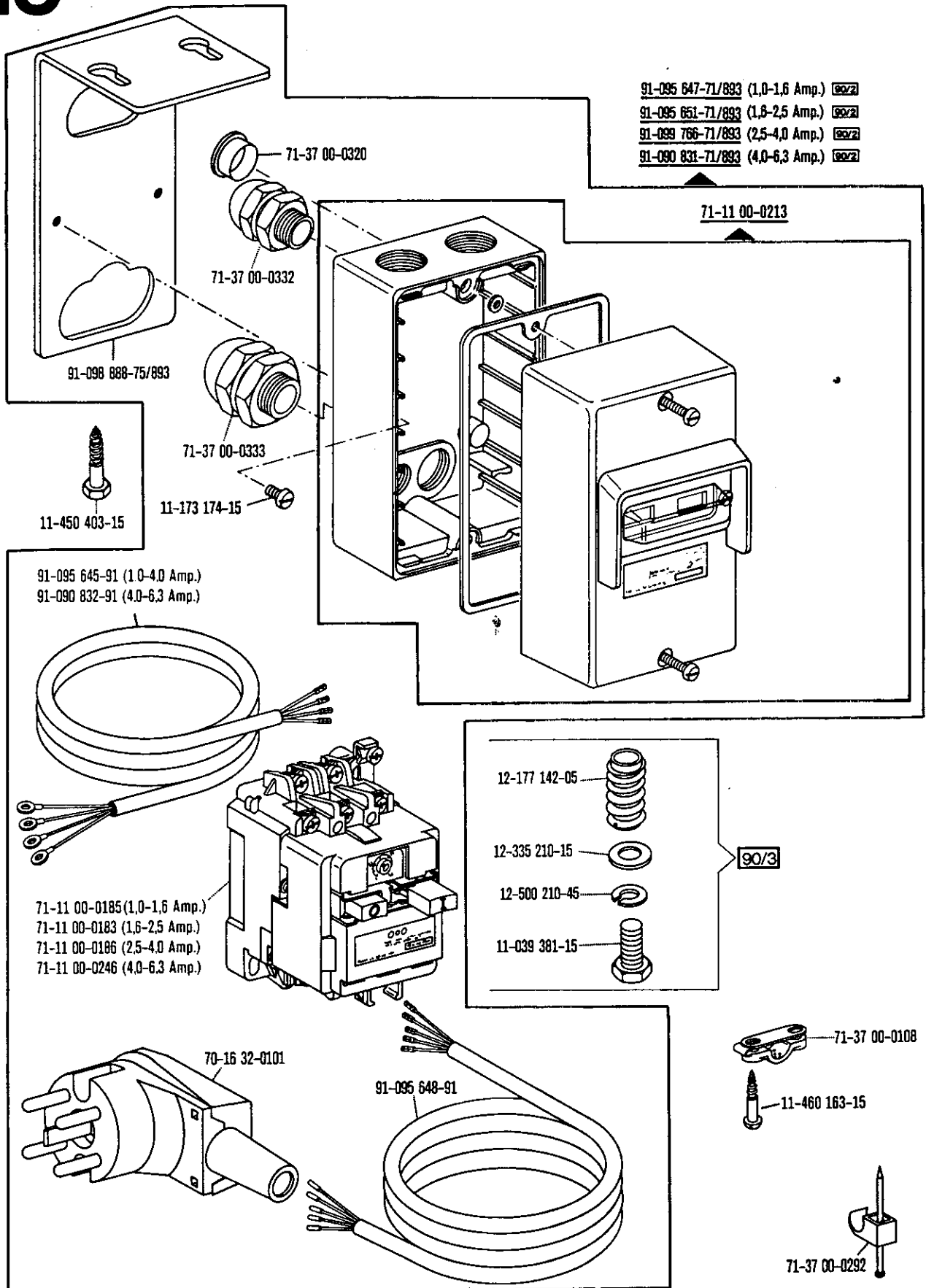

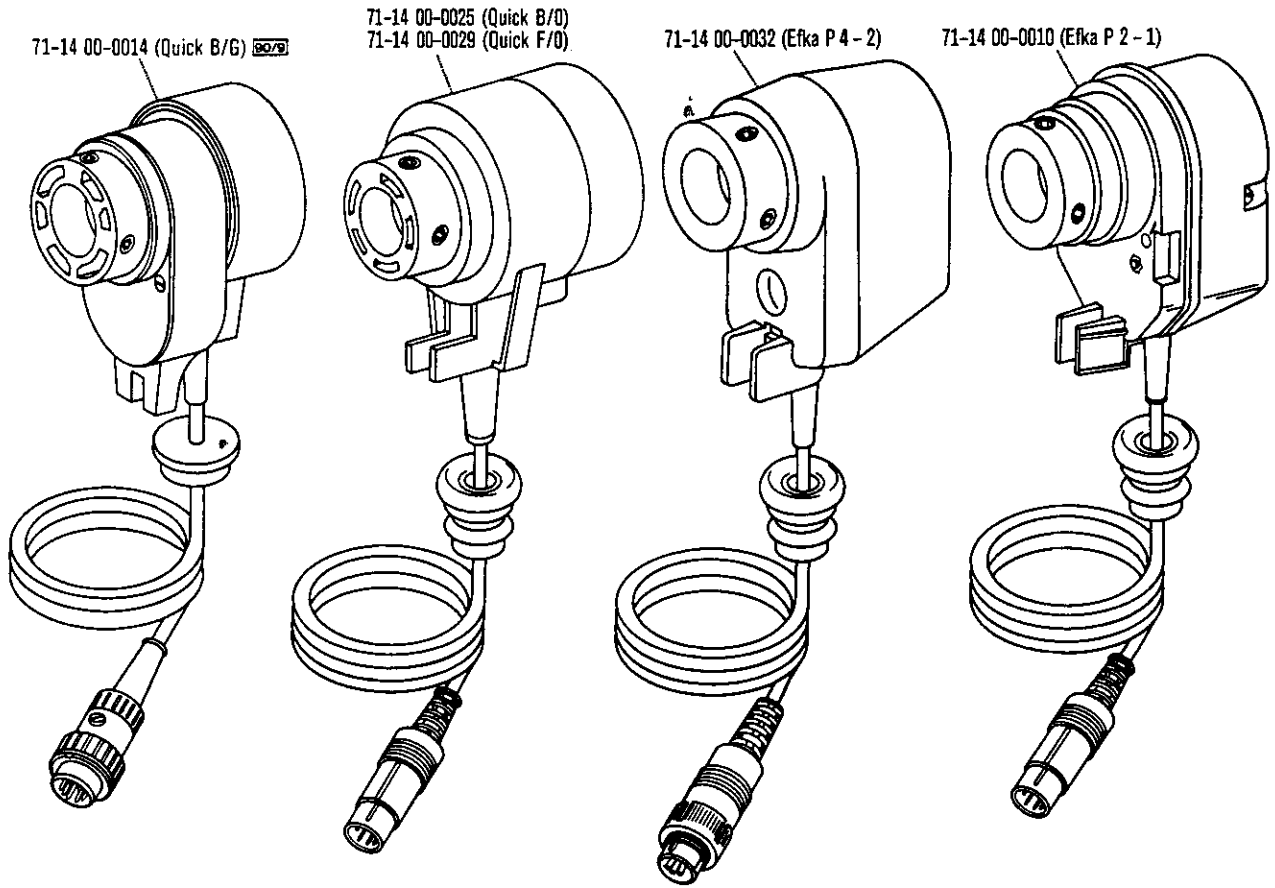
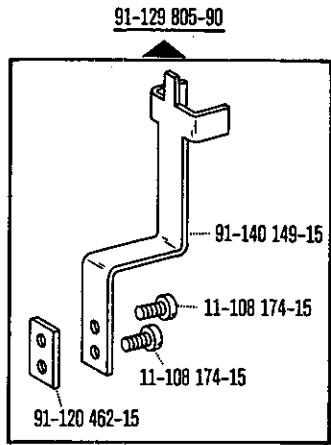

 siehe Erläuterungen Register 0
see explanations in section 0
voir légende registre 0

Keilriemenscheiben-Tabelle
Tableau des poulies à gorge en V
Table of V-belt pulleys
Tabla de poleas para correas en "V"

| Nähgeschwindigkeit max., Stiche/min Maximum sewing speed in s.p.m. Nombre de points max./mn Número máx. de puntadas por minuto | Motordrehzahl U/min Motor speed in r.p.m. Régime moteur en tours/min Régimen del motor en r.p.m. | Frequenz Frequency Fréquence Frecuencia | Handrad-Durchmesser ¹⁾ in mm Balance wheel diameter ¹⁾ in mm Diamètre du volant ¹⁾ en mm Diámetro del volante ¹⁾ en mm | Keilriemenscheiben-Durchmesser ¹⁾ in mm V-belt pulley diameter ¹⁾ in mm Diamètre de la poulie à gorge ¹⁾ en mm Diámetro de la polea para correa en "V" ¹⁾ en mm | Teilnummer der Keilriemenscheibe Part number of V-belt pulley Numéro de pièce des poulies à gorge en V Nº de las piezas de poleas para correas en "V" |
|---|---|--|---|---|--|
| 2800 | 2800 | 50 Hz | 75 | 75 | 16-437 040-55 |
| 2800 | 1700 | 60 Hz | 75 | 125 | 16-437 130-55 |
| 2400 | 1400 | 50 Hz | 75 | 132 | 16-437 901-55 |
| 2400 | 1700 | 60 Hz | 75 | 106 | 16-437 100-55 |
| 1800 | 2800 | 50 Hz | 120 | 75 | 16-437 040-55 |
| 1800 | 3400 | 60 Hz | 120 | 63 | 16-437 010-55 |
| 1800 | 1400 | 50 Hz | 75 | 95 | 16-437 080-55 |
| 1800 | 1700 | 60 Hz | 75 | 80 | 16-437 050-55 |
| 1600 | 1400 | 50 Hz | 75 | 85 | 16-437 060-55 |
| 1600 | 1700 | 60 Hz | 75 | 71 | 16-437 030-55 |
| 1400 | 1400 | 50 Hz | 75 | 75 | 16-437 040-55 |
| 1400 | 1700 | 60 Hz | 75 | 63 | 16-437 010-55 |
| 1200 | 1400 | 50 Hz | 75 | 63 | 16-437 010-55 |
| 1200 | 1700 | 60 Hz | 75 | 50 | 16-437 908-55 |
| | | | | | |
| | | | | | |
| | | | | | |
| | | | | | |
| | | | | | |
| | | | | | |
| | | | | | |
| | | | | | |
| | | | | | |
| | | | | | |
| | | | | | |
| | | | | | |
| | | | | | |
| | | | | | |

| No. | Seite Page Pages Página | No. | Seite Page Pages Página | No. | Seite Page Pages Página | No. | Seite Page Pages Página |
|---------------|---|---------------|----------------------------------|---------------|----------------------------------|---------------|--------------------------------------|
| 00-136 005-00 | 47 | 11-130 311-15 | 45 | 11-315 920-05 | 14 | 12-305 144-15 | 10, 15, 20, 25, 26, 36, 45, 48 |
| 11-039 381-15 | 54 | 11-130 341-15 | 11, 50, 51, 52 | 11-317 949-15 | 36 | 12-305 174-15 | 42 |
| 11-084 357-15 | 27, 50, 51 | 11-130 359-15 | 14, 24 | 11-317 950-15 | 26, 38, 40 | 12-305 224-15 | 37 |
| 11-106 947-15 | 41 | 11-130 371-15 | 27, 37 | 11-330 082-15 | 11 | 12-305 414-15 | 46 |
| 11-108 006-15 | 33 | 11-130 401-15 | 41 | 11-330 166-15 | 36 | 12-315 170-15 | 11, 21 |
| 11-108 093-15 | 11, 20 | 11-130 452-15 | 19, 31, 37 | 11-330 217-15 | 17, 35 | 12-335 151-15 | 11, 19, 21, 37 |
| 11-108 168-15 | 41, 49 | 11-130 914-15 | 45 | 11-330 220-15 | 10, 20, 36 | 12-335 191-15 | 39, 43, 45 |
| 11-108 171-15 | 10, 16, 20, 34, 41 | 11-132 905-15 | 11, 20 | 11-330 952-15 | 18, 30, 32 | 12-335 210-15 | 54 |
| 11-108 174-15 | 10, 16, 19, 20, 34, 36, 37, 39, 43, 44, 55 | 11-133 451-15 | 37 | 11-330 964-15 | 15, 16, 25, 28, 34 | 12-341 090-15 | 32 |
| 11-108 177-15 | 10 | 11-135 292-15 | 42 | 11-335 902-15 | 15, 17, 25, 29, 35 | 12-341 150-15 | 16, 28, 34 |
| 11-108 180-15 | 18 | 11-135 451-15 | 19, 31 | 11-341 169-15 | 34 | 12-500 151-45 | 39, 43 |
| 11-108 222-15 | 10, 20, 32, 36, 49 | 11-173 174-15 | 53, 54 | 11-341 901-15 | 17, 29, 35 | 12-500 190-45 | 38, 40 |
| 11-108 225-15 | 18, 19, 20, 30, 37, 48 | 11-173 222-15 | 12, 22 | 11-341 902-15 | 15, 17, 25, 29, 35, 36 | 12-500 210-45 | 54 |
| 11-108 228-15 | 10, 11, 18, 19, 21, 30, 31, 36, 37, 41 | 11-174 086-15 | 20, 49 | 11-341 905-15 | 26, 32, 38, 40 | 12-501 190-45 | 35, 42 |
| 11-108 240-15 | 19, 31, 37 | 11-174 173-15 | 10 | 11-450 403-15 | 53, 54 | 12-510 110-45 | 36 |
| 11-108 285-15 | 19, 31, 37 | 11-174 232-15 | 27, 50, 51 | 11-460 118-15 | 47 | 12-510 171-45 | 19, 37 |
| 11-108 285-25 | 48 | 11-174 287-15 | 35 | 11-460 157-15 | 39 | 12-515 250-05 | 20 |
| 11-108 294-15 | 11 | 11-174 293-15 | 36 | 11-460 163-15 | 54 | 12-610 170-45 | 10 |
| 11-108 363-15 | 15 | 11-174 914-05 | 36 | 11-460 406-15 | 50, 51 | 12-610 190-45 | 10 |
| 11-108 861-25 | 36 | 11-187 017-15 | 26 | 11-721 482-15 | 16, 28, 34 | 12-610 200-45 | 10 |
| 11-130 089-15 | 33 | 11-187 019-15 | 27 | 12-005 195-15 | 38, 40, 42, 46 | 12-610 210-45 | 22 |
| 11-130 185-15 | 33 | 11-210 048-15 | 11, 20 | 12-024 151-15 | 11, 21 | 12-610 230-45 | 16, 34 |
| 11-130 191-15 | 39, 43 | 11-210 168-25 | 14, 24 | 12-024 171-15 | 36, 46 | 12-610 240-45 | 16, 34 |
| 11-130 197-15 | 11, 20 | 11-210 207-15 | 38, 40 | 12-024 191-15 | 27, 35, 39, 43 | 12-610 310-45 | 27 |
| 11-130 224-15 | 34, 36 | 11-210 222-15 | 38, 40 | 12-024 191-25 | 47 | 12-640 130-55 | 14, 17, 24, 29, 32, 35 |
| 11-130 227-15 | 13, 15, 23, 25 | 11-210 239-15 | 19, 37 | 12-024 192-15 | 36 | 12-640 150-55 | 17, 29, 32, 36 |
| 11-130 233-15 | 36 | 11-210 273-15 | 15, 25 | 12-024 211-15 | 52 | 12-640 170-55 | 36 |
| 11-130 239-15 | 46 | 11-210 936-15 | 49 | 12-024 223-15 | 41 | 12-640 200-55 | 26, 32, 38, 40 |
| 11-130 245-15 | 36 | 11-250 084-25 | 14, 24 | 12-085 170-15 | 36 | 12-640 230-55 | 11, 50, 51, 52 |
| 11-130 293-15 | 38, 39, 40, 43 | 11-305 239-15 | 36 | 12-160 193-25 | 11, 21 | 12-642 170-45 | 26 |
| 11-130 299-15 | 27, 42 | 11-310 463-15 | 42 | 12-177 142-05 | 54 | 12-650 008-55 | 37 |
| | | 11-314 082-15 | 10, 20 | 12-305 114-15 | 10, 11, 20, 49 | 13-050 013-15 | 16, 34 |
| | | 11-315 917-05 | 14, 24 | 12-305 114-25 | 41 | | |

| No. | Seite Page Pages Página | No. | Seite Page Pages Página | No. | Seite Page Pages Página | No. | Seite Page Pages Página |
|---------------|----------------------------------|---------------|----------------------------------|---------------|--|---------------|----------------------------------|
| 13-052 319-15 | 34 | 16-437 908-55 | 56 | 71-37 00-0133 | 44 | 91-000 503-15 | 18, 30 |
| 13-052 340-15 | 37 | 18-277 001-91 | 39, 43 | 71-37 00-0292 | 54 | 91-000 510-15 | 13, 20, 23, 24, 41 |
| 13-052 983-15 | 49 | 18-278 005-91 | 39, 43 | 71-37 00-0306 | 44 | 91-000 511-15 | 24 |
| 13-060 400-05 | 19, 31, 37 | 18-279 010-05 | 39, 43 | 71-37 00-0320 | 53, 54 | 91-000 522-15 | 13, 23 |
| 13-064 383-05 | 13, 23 | 18-372 001-91 | 39, 43 | 71-37 00-0332 | 53, 54 | 91-000 524-05 | 12, 22 |
| 13-065 199-05 | 14, 24 | 18-373 011-91 | 39, 43 | 71-37 00-0333 | 53, 54 | 91-000 525-15 | 29 |
| 13-065 259-05 | 18, 30 | 18-378 001-91 | 38, 39, 40, 42, 43 | 91-000 011-15 | 14, 24 | 91-000 529-15 | 17, 29, 33 |
| 13-070 981-05 | 27 | 18-378 002-91 | 39, 43 | 91-000 059-25 | 13, 23 | 91-000 636-25 | 20 |
| 14-016 080-01 | 15, 25 | 40-754 701-00 | 47 | 91-000 063-15 | 12, 22 | 91-000 645-05 | 20 |
| 14-017 121-91 | 15, 25 | 61-111 600-01 | 48 | 91-000 072-15 | 10, 21 | 91-000 654-15 | 12, 22 |
| 14-215 007-13 | 10 | 61-111 600-35 | 48 | 91-000 073-15 | 28 | 91-000 660-15 | 13, 23 |
| 14-215 013-13 | 10 | 70-16 31-5111 | 53 | 91-000 082-15 | 12, 22, 30 | 91-000 666-05 | 12, 22 |
| 14-215 022-13 | 10 | 70-16 32-0101 | 54 | 91-000 082-25 | 18, 19, 30, 31, 37 | 91-000 672-15 | 13, 23 |
| 14-215 022-43 | 12 | 70-37 70-0006 | 39, 42, 43 | 91-000 083-15 | 20 | 91-000 699-15 | 28 |
| 14-215 046-43 | 12 | 71-11 00-0183 | 53, 54 | 91-000 150-15 | 10, 12, 14, 17, 20, 22, 24, 29, 35 | 91-000 715-25 | 13, 23 |
| 14-215 049-13 | 10 | 71-11 00-0185 | 54 | 91-000 152-15 | 10, 13, 21, 23, 41 | 91-000 741-15 | 15 |
| 14-215 049-43 | 17, 29, 35 | 71-11 00-0186 | 53, 54 | 91-000 172-25 | 12, 22, 49 | 91-000 783-15 | 18, 30 |
| 14-215 238-43 | 11, 21 | 71-11 00-0213 | 53, 54 | 91-000 237-15 | 20 | 91-000 790-15 | 28 |
| 14-602 901-01 | 14, 24 | 71-11 00-0246 | 53, 54 | 91-000 239-15 | 12, 22 | 91-000 809-15 | 18, 30 |
| 14-650 104-05 | 20 | 71-11 00-0262 | 53 | 91-000 243-15 | 12, 22 | 91-000 928-15 | 17, 29, 33 |
| 14-755 043-01 | 38, 40 | 71-13 00-0439 | 44 | 91-000 263-15 | 19, 37 | 91-000 929-15 | 19, 31 |
| 15-032 001-45 | 38, 39, 40, 42, 43 | 71-13 00-0440 | 44 | 91-000 278-15 | 20, 33 | 91-001 013-15 | 14, 24 |
| 15-711 050-51 | 11, 21 | 71-14 00-0010 | 55 | 91-000 290-15 | 18, 30 | 91-001 283-15 | 50, 51 |
| 16-410 918-05 | 15, 25 | 71-14 00-0014 | 55 | 91-000 335-25 | 12, 22 | 91-001 512-15 | 13, 14, 23, 24 |
| 16-437 010-55 | 56 | 71-14 00-0025 | 55 | 91-000 366-15 | 12, 22 | 91-001 513-15 | 26, 52 |
| 16-437 030-55 | 56 | 71-14 00-0029 | 55 | 91-000 390-15 | 17, 29, 33 | 91-001 522-25 | 12, 22 |
| 16-437 040-55 | 56 | 71-14 00-0032 | 55 | 91-000 405-15 | 24 | 91-001 536-15 | 18, 30 |
| 16-437 050-55 | 56 | 71-16 00-0118 | 39, 43 | 91-000 407-15 | 18, 30, 33 | 91-001 593-25 | 13, 23 |
| 16-437 060-55 | 56 | 71-16 00-0208 | 42, 44 | 91-000 412-25 | 12, 22 | 91-001 734-15 | 41 |
| 16-437 080-55 | 56 | 71-17 00-0131 | 36 | 91-000 422-25 | 18, 30, 33 | 91-001 758-05 | 20 |
| 16-437 100-55 | 56 | 71-21 00-0125 | 36 | 91-000 456-15 | 24 | 91-004 005-05 | 12, 22, 49 |
| 16-437 130-55 | 56 | 71-37 00-0108 | 54 | 91-000 469-15 | 10, 20 | 91-004 006-05 | 12, 22, 49 |
| 16-437 901-55 | 56 | 71-37 00-0132 | 36 | | | 91-004 186-15 | 18, 30 |

| No. | Seite Page Pages Página | No. | Seite Page Pages Página | No. | Seite Page Pages Página | No. | Seite Page Pages Página |
|-------------------|----------------------------------|-------------------|----------------------------------|-------------------|----------------------------------|-------------------|----------------------------------|
| 91-004 309-05 | 10 | 91-009 612-15 | 13, 23 | 91-010 644-15 | 52 | 91-014 679-25 | 49 |
| 91-005 544-05 | 14, 24 | 91-009 616-05 | 13, 23, 41 | 91-010 646-71/895 | 21 | 91-014 680-91 | 49 |
| 91-005 673-05 | 18, 30 | 91-009 617-05 | 13, 23, 41 | 91-010 703-92 | 12, 22 | 91-015 527-05 | 22 |
| 91-005 694-01 | 14, 24 | 91-009 618-05 | 13, 23, 41 | 91-010 704-15 | 18, 30 | 91-015 664-05 | 18, 30 |
| 91-006 505-05 | 12, 22 | 91-009 624-05 | 13, 23, 41 | 91-010 736-15 | 20 | 91-018 136-12 | 18, 30 |
| 91-006 759-05 | 13, 23 | 91-009 633-92 | 13, 23, 41 | 91-010 817-90 | 49 | 91-018 147-05 | 33, 47 |
| 91-007 015-05 | 12 | 91-009 648-25 | 13, 23 | 91-010 817-91 | 49 | 91-018 157-15 | 36 |
| 91-007 116-05 | 10 | 91-009 652-91 | 12, 22 | 91-010 819-25 | 49 | 91-018 224-75/951 | 37 |
| 91-008 008-92 | 22 | 91-009 690-71/698 | 13, 23 | 91-010 820-45 | 49 | 91-018 225-11 | 32 |
| 91-008 011-05 | 22 | 91-010 013-05 | 14, 15, 24 | 91-010 821-25 | 49 | 91-018 261-05 | 29 |
| 91-008 021-11 | 20 | 91-010 022-05 | 13, 23 | 91-010 825-05 | 10 | 91-018 273-70/895 | 41 |
| 91-008 064-05 | 22 | 91-010 026-21 | 12, 22 | 91-010 937-05 | 12, 22 | 91-018 293-05 | 17, 29, 33 |
| 91-008 470-05 | 14, 24 | 91-010 056-05 | 16, 28, 34 | 91-010 942-05 | 22 | 91-018 339-05 | 17, 29, 47 |
| 91-009 009-05 | 20 | 91-010 062-72/895 | 33 | 91-011 727-05 | 21 | 91-018 340-91 | 29 |
| 91-009 148-05 | 12, 22 | 91-010 107-05 | 12, 22 | 91-011 729-92 | 20 | 91-018 341-91 | 29 |
| 91-009 149-05 | 18, 30 | 91-010 115-05 | 12, 22, 49 | 91-011 730-15 | 20 | 91-018 344-05 | 29 |
| 91-009 335-75/895 | 19, 31 | 91-010 116-05 | 12, 22, 49 | 91-011 731-05 | 20 | 91-018 346-01 | 17, 29 |
| 91-009 343-05 | 17, 29, 35 | 91-010 120-05 | 28 | 91-011 739-92 | 20 | 91-018 348-91 | 17, 29 |
| 91-009 359-91 | 18, 30 | 91-010 126-92 | 18, 30 | 91-011 746-05 | 21 | 91-018 349-05 | 17, 29 |
| 91-009 391-21 | 12, 22 | 91-010 146-92 | 18, 30 | 91-011 752-12 | 21 | 91-018 350-05 | 17, 29, 33 |
| 91-009 408-05 | 17, 29, 35 | 91-010 181-25 | 12, 22 | 91-011 754-05 | 12, 22 | 91-018 358-75/770 | 14, 24 |
| 91-009 498-70/895 | 13, 23 | 91-010 184-05 | 12, 22 | 91-011 778-05 | 11, 21 | 91-018 404-05 | 28 |
| 91-009 499-71/895 | 13, 23 | 91-010 185-05 | 12, 22 | 91-012 492-25 | 13 | 91-018 406-01 | 28 |
| 91-009 500-71/895 | 13 | 91-010 186-15 | 12, 22 | 91-013 040-92 | 14, 24 | 91-018 439-05 | 17, 29, 33 |
| 91-009 577-70/895 | 41 | 91-010 196-05 | 14, 24 | 91-013 080-15 | 32 | 91-018 467-70/895 | 13 |
| 91-009 599-05 | 41 | 91-010 211-05 | 18, 30 | 91-013 086-12 | 36 | 91-018 480-05 | 33, 47 |
| 91-009 602-02 | 13, 23 | 91-010 221-05 | 18, 30 | 91-013 090-05 | 32 | 91-018 487-05 | 14, 24 |
| 91-009 603-75/895 | 13, 23 | 91-010 360-05 | 21 | 91-013 091-05 | 12, 22 | 91-018 600-01 | 28 |
| 91-009 604-05 | 13, 23, 41 | 91-010 538-05 | 41 | 91-013 153-05 | 17, 29, 35 | 91-018 638-92 | 36 |
| 91-009 605-05 | 13, 23, 41 | 91-010 596-05 | 13, 14, 24 | 91-013 188-05 | 17, 29, 35 | 91-018 662-75/895 | 19 |
| 91-009 606-05 | 13, 23 | 91-010 633-05 | 20 | 91-013 191-05 | 12, 22 | 91-018 885-15 | 33 |
| 91-009 609-05 | 13, 23 | 91-010 636-75/895 | 21 | 91-013 192-15 | 32 | 91-018 891-75/895 | 37 |
| 91-009 610-71/698 | 13, 23 | 91-010 643-15 | 52 | 91-013 193-91 | 12, 22 | 91-018 961-71/894 | 38, 40 |

| No. | Seite Page Pages Página | No. | Seite Page Pages Página | No. | Seite Page Pages Página | No. | Seite Page Pages Página |
|-------------------|----------------------------------|-------------------|----------------------------------|-------------------|----------------------------------|-------------------|----------------------------------|
| 91-018 964-71/894 | 38, 40 | 91-029 355-21 | 50, 51 | 91-069 335-72/893 | 27 | 91-095 985-91 | 53 |
| 91-018 987-75/895 | 38, 40 | 91-029 394-01 | 47 | 91-082 878-15 | 38, 40 | 91-095 997-71/893 | 53 |
| 91-019 118-71/851 | 28 | 91-029 692-75/792 | 27, 50, 51 | 91-083 761-71/895 | 41 | 91-097 149-15 | 39 |
| 91-019 120-90 | 28 | 91-029 811-05 | 47 | 91-083 762-75/895 | 41 | 91-098 888-75/893 | 53, 54 |
| 91-019 122-05 | 29 | 91-029 946-91 | 47 | 91-083 763-11 | 41 | 91-099 766-71/893 | 54 |
| 91-019 123-70/756 | 28 | 91-031 009-75/893 | 50, 51 | 91-083 764-11 | 41 | 91-099 811-05 | 44 |
| 91-019 657-05 | 20 | 91-031 409-12 | 50, 51 | 91-083 765-15 | 41 | 91-099 904-45 | 36 |
| 91-019 676-05 | 13, 14, 22, 23, 24 | 91-031 458-51 | 42 | 91-083 766-15 | 41 | 91-100 213-05 | 12 |
| 91-019 735-15 | 26 | 91-031 459-75/894 | 38, 40 | 91-083 789-05 | 41 | 91-100 270-25 | 44 |
| 91-019 891-05 | 17, 33 | 91-033 224-15 | 50, 51 | 91-084 100-71/689 | 49 | 91-100 281-25 | 14, 24 |
| 91-019 959-92 | 24 | 91-033 915-21 | 48 | 91-084 115-05 | 49 | 91-100 360-15 | 14 |
| 91-021 486-41 | 52 | 91-033 921-21 | 48 | 91-084 116-15 | 49 | 91-100 366-15 | 10, 20 |
| 91-022 672-05 | 13, 14, 23, 24 | 91-038 800-71/699 | 48 | 91-084 134-70/689 | 49 | 91-100 373-15 | 42 |
| 91-023 505-25 | 49 | 91-038 801-75/699 | 48 | 91-084 314-25 | 41 | 91-100 396-15 | 17, 33 |
| 91-025 055-15 | 50 | 91-038 803-75/699 | 48 | 91-089 095-91 | 44 | 91-102 007-92 | 13, 41 |
| 91-025 164-05 | 26 | 91-038 885-91 | 48 | 91-089 096-25 | 44 | 91-102 033-05 | 13, 41 |
| 91-025 169-72/893 | 50, 51 | 91-056 192-25 | 47 | 91-090 583-71/893 | 53 | 91-105 447-25 | 12, 22 |
| 91-025 170-15 | 50, 51 | 91-056 193-25 | 47 | 91-090 584-71/893 | 53 | 91-106 401-05 | 36 |
| 91-025 637-15 | 49 | 91-056 578-91 | 47 | 91-090 585-91 | 53 | 91-107 204-15 | 36 |
| 91-027 289-15 | 27 | 91-056 579-21 | 47 | 91-090 586-91 | 53 | 91-107 249-45 | 41 |
| 91-027 370-05 | 27, 50, 51 | 91-057 697-91 | 10, 20 | 91-090 831-71/893 | 54 | 91-107 615-75/895 | 37 |
| 91-027 371-12 | 27, 50, 51 | 91-057 720-15 | 10, 20 | 91-090 832-91 | 54 | 91-107 629-05 | 26, 32, 38, 40 |
| 91-027 373-72/698 | 50, 51 | 91-057 721-91 | 10, 20 | 91-093 063-05 | 44 | 91-107 657-05 | 36 |
| 91-027 387-91 | 52 | 91-057 741-91 | 10 | 91-095 645-91 | 54 | 91-107 663-05 | 37 |
| 91-027 388-70/893 | 50 | 91-057 742-91 | 10 | 91-095 647-71/893 | 54 | 91-107 665-15 | 51 |
| 91-027 389-70/893 | 51 | 91-061 005-05 | 20 | 91-095 648-91 | 54 | 91-107 695-91 | 15, 25 |
| 91-027 624-91 | 5 | 91-063 007-01 | 13, 23 | 91-095 651-71/893 | 54 | 91-107 696-15 | 15, 25 |
| 91-027 630-91 | 5 | 91-063 047-05 | 13, 23 | 91-095 829-91 | 39, 43 | 91-107 776-05 | 36 |
| 91-027 651-75/699 | 48 | 91-063 048-05 | 10, 12, 22 | 91-095 837-91 | 42 | 91-107 777-12 | 36 |
| 91-028 953-15 | 52 | 91-063 049-05 | 12 | 91-095 850-91 | 36 | 91-107 886-15 | 41 |
| 91-029 007-91 | 47 | 91-063 051-01 | 12 | 91-095 982-71/893 | 53 | 91-107 925-15 | 35 |
| 91-029 033-45 | 47 | 91-069 037-15 | 17, 29, 35 | 91-095 983-91 | 53 | 91-107 927-15 | 35 |
| 91-029 036-70/894 | 46 | 91-069 043-15 | 22 | 91-095 984-91 | 53 | 91-107 928-91 | 35 |

| No. | Seite Page Pages Página | No. | Seite Page Pages Página | No. | Seite Page Pages Página | No. | Seite Page Pages Página |
|-------------------|----------------------------------|-------------------|----------------------------------|-------------------|----------------------------------|-------------------|----------------------------------|
| 91-108 009-05 | 11, 21 | 91-129 456-91 | 5 | 91-140 067-02 | 24 | 91-140 180-91 | 33 |
| 91-108 010-15 | 11, 21 | 91-129 541-91 | 5 | 91-140 071-91 | 11, 20 | 91-140 182-12 | 35 |
| 91-108 015-02 | 14, 24 | 91-129 621-75/894 | 46 | 91-140 073-05 | 11, 20 | 91-140 184-91 | 36 |
| 91-108 596-15 | 52 | 91-129 637-75/894 | 46 | 91-140 076-25 | 20 | 91-140 199-02 | 16, 17, 33, 34 |
| 91-113 030-25 | 12, 22 | 91-129 640-70/894 | 46 | 91-140 077-25 | 20 | 91-140 200-75/893 | 12, 22 |
| 91-113 075-05 | 28 | 91-129 644-05 | 46 | 91-140 085-05 | 10, 20 | 91-140 201-05 | 34 |
| 91-113 144-15 | 26 | 91-129 645-75/698 | 46 | 91-140 086-12 | 10, 20 | 91-140 202-05 | 34 |
| 91-113 480-91 | 33, 47 | 91-129 649-45 | 46 | 91-140 087-05 | 21 | 91-140 241-15 | 16, 34 |
| 91-114 351-15 | 42 | 91-129 680-25 | 46 | 91-140 092-75/893 | 48 | 91-140 242-05 | 16, 34 |
| 91-118 067-25 | 18, 30 | 91-129 783-71/894 | 46 | 91-140 093-75/893 | 48 | 91-140 253-05 | 16 |
| 91-118 098-25 | 14, 24 | 91-129 784-71/894 | 46 | 91-140 095-05 | 12 | 91-140 255-05 | 34 |
| 91-118 099-91 | 14, 24 | 91-129 785-05 | 46 | 91-140 101-05 | 14, 24 | 91-140 256-05 | 17, 33 |
| 91-118 196-12 | 10 | 91-129 805-90 | 55 | 91-140 102-05 | 14, 24 | 91-140 257-05 | 17, 33 |
| 91-118 681-05 | 14, 24 | 91-129 916-91 | 5 | 91-140 104-05 | 17, 29, 35 | 91-140 258-05 | 17, 33 |
| 91-118 682-05 | 14, 24 | 91-129 917-91 | 5 | 91-140 117-75/698 | 19, 31, 37 | 91-140 259-05 | 18, 30 |
| 91-118 683-05 | 14, 24 | 91-129 919-91 | 5 | 91-140 119-05 | 14 | 91-140 260-91 | 18, 30 |
| 91-118 685-05 | 14, 24 | 91-129 920-91 | 5 | 91-140 120-05 | 15, 25 | 91-140 273-05 | 10 |
| 91-118 711-05 | 16, 17, 33, 34 | 91-129 941-91 | 5 | 91-140 121-91 | 15, 25 | 91-140 279-75/893 | 49 |
| 91-118 931-05 | 14, 24 | 91-130 865-05 | 42 | 91-140 122-91 | 17, 29, 35 | 91-140 286-05 | 33 |
| 91-118 934-91 | 14, 24 | 91-130 886-05 | 42 | 91-140 123-91 | 15, 25 | 91-140 287-91 | 33 |
| 91-118 935-05 | 14, 24 | 91-140 023-05 | 16, 28 | 91-140 124-11 | 15, 25 | 91-140 291-01 | 33 |
| 91-118 937-05 | 14, 24 | 91-140 035-71/895 | 19 | 91-140 127-05 | 15, 25 | 91-140 292-91 | 11 |
| 91-118 939-21 | 14, 24 | 91-140 036-71/895 | 19 | 91-140 129-72/895 | 31, 38, 40 | 91-140 293-92 | 11, 21 |
| 91-118 940-05 | 14, 24 | 91-140 036-75/895 | 37 | 91-140 133-72/893 | 15, 25 | 91-140 294-75/895 | 32 |
| 91-119 421-05 | 10 | 91-140 038-71/895 | 19 | 91-140 137-72/895 | 26 | 91-140 297-92 | 36 |
| 91-119 936-05 | 41 | 91-140 039-71/895 | 37 | 91-140 138-15 | 26, 32, 38, 40 | 91-140 300-01 | 16, 34 |
| 91-120 462-15 | 55 | 91-140 040-71/895 | 37 | 91-140 141-11 | 19 | 91-140 315-05 | 22 |
| 91-120 735-92 | 17, 29, 35 | 91-140 041-71/895 | 31 | 91-140 148-05 | 17, 29, 35 | 91-140 325-91 | 22 |
| 91-129 118-75/894 | 46 | 91-140 042-71/895 | 31 | 91-140 149-15 | 55 | 91-140 336-15 | 11, 38, 40 |
| 91-129 153-91 | 47 | 91-140 060-25 | 41 | 91-140 153-75/895 | 19, 31, 37 | 91-140 338-15 | 38, 40 |
| 91-129 159-70/894 | 46 | 91-140 061-15 | 41 | 91-140 155-11 | 37 | 91-140 342-01 | 10, 20 |
| 91-129 191-71/894 | 47 | 91-140 062-25 | 41 | 91-140 160-91 | 36 | 91-140 347-01 | 10 |
| 91-129 452-91 | 5 | 91-140 066-05 | 24 | 91-140 166-15 | 33 | 91-140 349-05 | 10, 20 |

| No. | Seite Page Pages Página | No. | Seite Page Pages Página | No. | Seite Page Pages Página | No. | Seite Page Pages Página |
|-------------------|----------------------------------|-------------------|----------------------------------|-------------------|----------------------------------|-------------------|----------------------------------|
| 91-140 351-91 | 10 | 91-140 453-05 | 17, 33 | 91-140 710-91 | 27 | 91-141 426-15 | 19, 37 |
| 91-140 352-05 | 10 | 91-140 457-15 | 32 | 91-140 711-15 | 27 | 91-141 427-15 | 19, 37 |
| 91-140 353-05 | 10 | 91-140 481-01 | 14, 24 | 91-140 712-11 | 27 | 91-141 428-15 | 19 |
| 91-140 354-11 | 10 | 91-140 501-91 | 42 | 91-140 715-05 | 27 | 91-141 429-15 | 31 |
| 91-140 358-05 | 10 | 91-140 512-91 | 35 | 91-140 720-15 | 27 | 91-141 430-15 | 31 |
| 91-140 359-05 | 10 | 91-140 516-75/770 | 14, 16, 24, 28, 34 | 91-140 722-71/951 | 28 | 91-141 432-15 | 37 |
| 91-140 360-05 | 10 | 91-140 517-05 | 35 | 91-140 725-15 | 16, 28, 34 | 91-141 438-05 | 20 |
| 91-140 361-15 | 10 | 91-140 532-05 | 12 | 91-140 726-01 | 34 | 91-141 439-11 | 26 |
| 91-140 362-05 | 10 | 91-140 533-05 | 12 | 91-140 728-92 | 34 | 91-141 441-15 | 27 |
| 91-140 363-12 | 10 | 91-140 534-01 | 12 | 91-140 731-90 | 34 | 91-141 442-15 | 12, 22 |
| 91-140 364-15 | 10 | 91-140 539-91 | 17 | 91-140 945-05 | 17, 33 | 91-141 443-15 | 12, 22 |
| 91-140 365-05 | 10 | 91-140 552-91 | 17, 33 | 91-140 987-05 | 34 | 91-141 452-12 | 14, 24 |
| 91-140 366-05 | 10 | 91-140 560-90 | 17, 29, 35 | 91-141 018-05 | 11, 20 | 91-141 454-91 | 14, 24 |
| 91-140 367-05 | 10 | 91-140 561-91 | 17, 29, 35 | 91-141 085-05 | 17 | 91-141 493-75/895 | 26 |
| 91-140 368-01 | 10 | 91-140 562-05 | 17, 35, 29 | 91-141 087-05 | 35 | 91-141 519-05 | 16, 34 |
| 91-140 371-05 | 10 | 91-140 563-05 | 17, 29, 35 | 91-141 099-05 | 10, 20 | 91-141 521-75/951 | 16 |
| 91-140 372-05 | 10 | 91-140 564-92 | 17, 29, 35 | 91-141 100-91 | 10 | 91-141 525-01 | 16 |
| 91-140 374-05 | 10 | 91-140 567-05 | 12 | 91-141 101-15 | 10 | 91-141 529-01 | 34 |
| 91-140 377-15 | 11, 21 | 91-140 574-05 | 12 | 91-141 102-05 | 10 | 91-141 534-75/951 | 34 |
| 91-140 378-05 | 11, 21 | 91-140 576-91 | 12 | 91-141 192-92 | 18 | 91-141 535-05 | 16, 34 |
| 91-140 379-92 | 11 | 91-140 578-92 | 14 | 91-141 193-92 | 15 | 91-141 536-90 | 16, 34 |
| 91-140 394-05 | 10 | 91-140 579-12 | 11 | 91-141 195-91 | 15 | 91-141 538-01 | 16, 34 |
| 91-140 403-91 | 13, 23, 41 | 91-140 582-15 | 11, 50, 51, 52 | 91-141 219-92 | 20 | 91-141 540-15 | 16, 34 |
| 91-140 404-91 | 13, 23, 41 | 91-140 583-72/895 | 19, 37 | 91-141 307-05 | 10, 20 | 91-141 541-05 | 16 |
| 91-140 405-91 | 13, 41 | 91-140 584-05 | 11 | 91-141 308-91 | 11, 20 | 91-141 542-05 | 16, 34 |
| 91-140 413-05 | 17, 33 | 91-140 585-05 | 10 | 91-141 309-05 | 11, 20 | 91-141 543-05 | 34 |
| 91-140 414-05 | 17, 33 | 91-140 597-15 | 10 | 91-141 310-05 | 11, 20 | 91-141 545-05 | 16, 34 |
| 91-140 415-05 | 17, 33 | 91-140 619-15 | 42 | 91-141 311-05 | 11, 20 | 91-141 546-05 | 16, 34 |
| 91-140 418-05 | 16 | 91-140 622-15 | 42 | 91-141 312-71/951 | 10 | 91-141 547-05 | 16, 34 |
| 91-140 419-05 | 34 | 91-140 661-72/895 | 38, 40 | 91-141 313-75/951 | 10 | 91-141 550-71/951 | 16 |
| 91-140 425-75/895 | 19, 31, 37 | 91-140 662-12 | 11 | 91-141 316-71/951 | 20 | 91-141 554-71/951 | 34 |
| 91-140 450-25 | 10 | 91-140 679-92 | 11 | 91-141 317-75/951 | 20 | 91-141 563-01 | 16, 34 |
| 91-140 451-91 | 33 | 91-140 709-91 | 21 | 91-141 425-15 | 19, 37 | 91-141 566-71/951 | 16 |

| No. | Seite Page Pages Página | No. | Seite Page Pages Página | No. | Seite Page Pages Página | No. | Seite Page Pages Página |
|-------------------|----------------------------------|-------------------|----------------------------------|----------------|----------------------------------|-----|----------------------------------|
| 91-141 570-71/951 | 34 | 91-175 586-71/894 | 38, 40 | 99-135 350-91 | 39, 43 | | |
| 91-141 572-12 | 18, 30 | 91-175 614-05 | 20 | 99-136 489-91 | 45 | | |
| 91-141 573-75/951 | 18, 30 | 91-176 051-71/893 | 43 | 99-136 558-91 | 45 | | |
| 91-166 452-21 | 47 | 91-176 332-25 | 12, 22 | 99-136 559-91 | 45 | | |
| 91-167 553-11 | 36 | 91-177 464-75/893 | 39, 43 | 99-136 560-91 | 45 | | |
| 91-167 559-05 | 36 | 91-187 293-75/893 | 45 | 99-136 675-91 | 45 | | |
| 91-167 560-05 | 36 | 91-700 029-15 | 26 | 99-136 676-91 | 45 | | |
| 91-167 636-05 | 36 | 91-700 388-15 | 49 | 99-136 677-05 | 45 | | |
| 91-168 025-05 | 12 | 91-700 412-25 | 19, 31, 37, 38, 40 | 99-136 678-05 | 45 | | |
| 91-168 319-12 | 11, 16, 28, 34, 35 | 91-700 510-15 | 11, 14, 21, 36 | 99-136 680-91 | 45 | | |
| 91-168 321-05 | 10 | 91-700 687-15 | 13, 23, 41 | 280-1-120 122 | 5 | | |
| 91-168 322-05 | 10 | 91-700 689-15 | 14, 17, 18, 24, 29, 35 | 280-1-120 144 | 5 | | |
| 91-168 331-05 | 27 | 91-700 785-15 | 11, 16, 28, 34, 35 | 280-1-120 205 | 5 | | |
| 91-168 375-70/893 | 27 | 91-700 961-15 | 13, 23, 41 | 280-1-120 217 | 5 | | |
| 91-168 376-15 | 27 | 91-701 319-25 | 49 | 280-1-120 243 | 5 | | |
| 91-168 415-15 | 36 | 91-710 484-92 | 49 | 280-1-120 247 | 5 | | |
| 91-168 480-15 | 15, 25 | 95-627 480-15 | 42 | 24 101-2.205-4 | 39, 43, 44 | | |
| 91-168 906-02 | 36 | 96-711 962-05 | 10 | 24 132-2.204-4 | 42 | | |
| 91-168 907-05 | 36 | 97-30 117-325/893 | 47 | 25 308-8.204-0 | 39, 42, 43, 45 | | |
| 91-168 909-15 | 36 | 99-115 034-15 | 46 | 25 308-8.206-0 | 39, 43, 45 | | |
| 91-168 910-05 | 36 | 99-115 037-45 | 46 | 26 534-3.005-0 | 12, 13, 14, 22, 23, 24 | | |
| 91-168 934-05 | 36 | 99-115 411-91 | 45 | | | | |
| 91-168 934-92 | 36 | 99-133 752-01 | 39, 43 | | | | |
| 91-171 042-05 | 14, 24 | 99-134 008-91 | 39, 42, 43 | | | | |
| 91-171 049-05 | 14, 24 | 99-134 089-05 | 49 | | | | |
| 91-171 808-05 | 10 | 99-134 093-05 | 49 | | | | |
| 91-173 664-15 | 11 | 99-134 299-91 | 39, 43 | | | | |
| 91-174 783-05 | 14, 24 | 99-134 369-91 | 39, 43 | | | | |
| 91-174 879-05 | 47 | 99-134 373-91 | 42 | | | | |
| 91-175 023-05 | 17, 29, 35 | 99-134 452-91 | 39, 43 | | | | |
| 91-175 023-15 | 17 | 99-135 062-91 | 38, 40 | | | | |
| 91-175 126-05 | 17, 29, 35 | 99-135 161-85 | 16, 34 | | | | |
| 91-175 514-71/893 | 39 | 99-135 188-85 | 41 | | | | |